

Protein Microarrays?

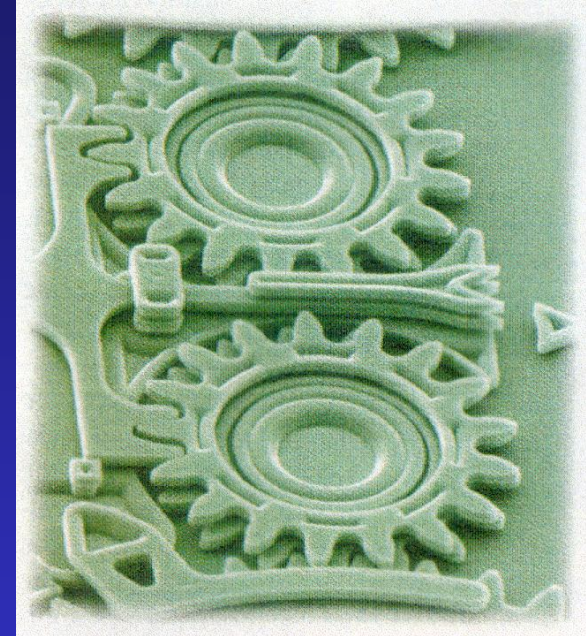

Protein Chemistry/Proteomics Unit and the Neuroscience Program, Biomedicum Helsinki

E-Mail: marc.baumann@helsinki.fi

<http://research.med.helsinki.fi/corefacilities/proteinchem>

HOW PROTEOMICS CAN HELP DRUG DEVELOPMENT

FINDING NEW DRUG TARGETS

(Here, devising a drug to kill the skin cancer melanoma)

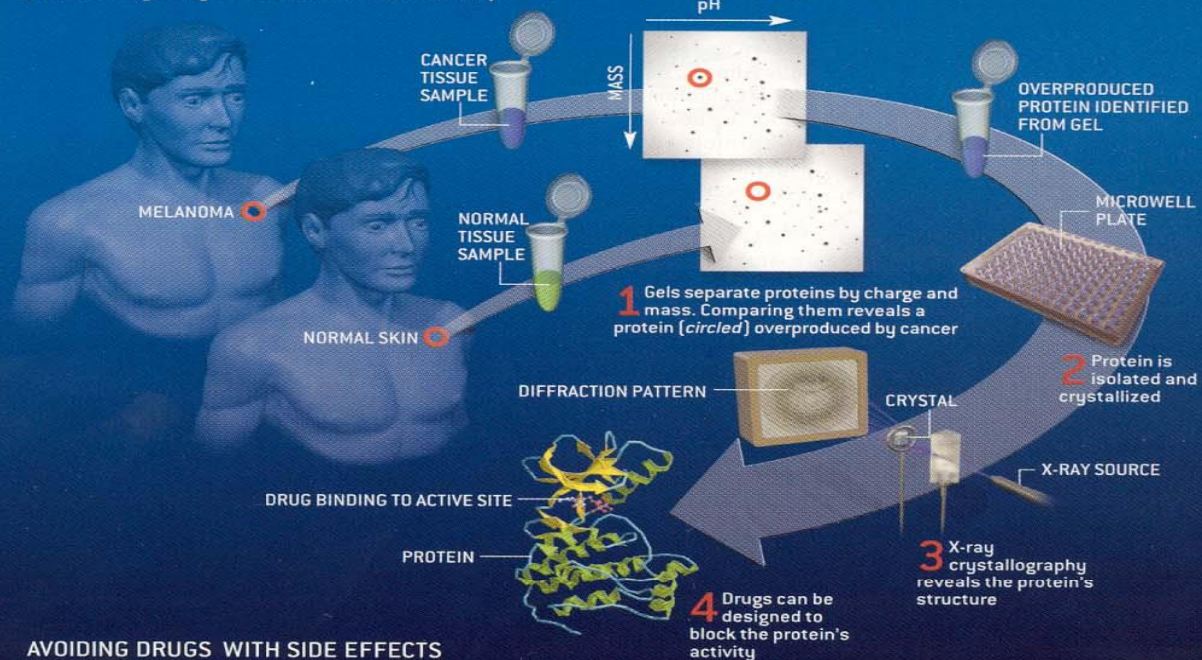

AVOIDING DRUGS WITH SIDE EFFECTS

(Here, determining whether an investigational drug prompts production of possibly harmful proteins)

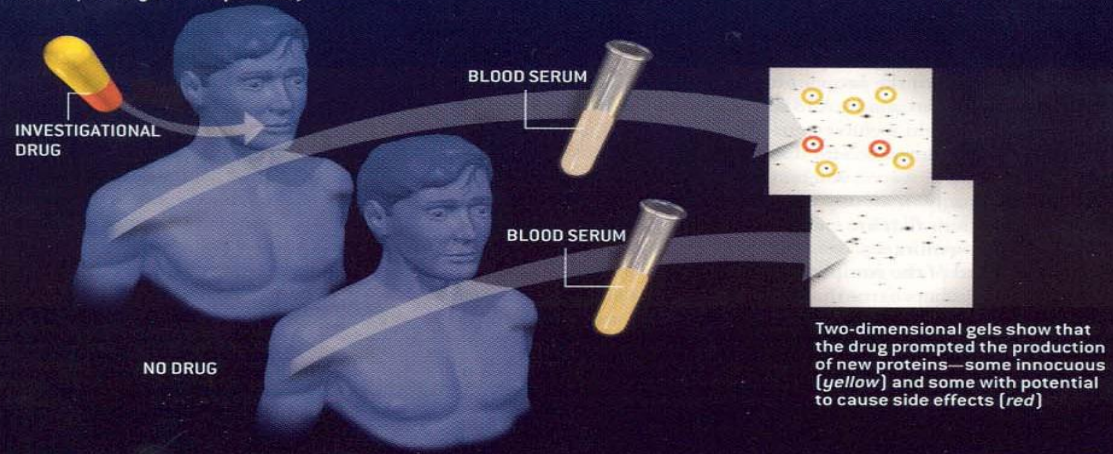

IN FILMS (preceding pages)

IN FILMS; PROTEIN/DRUG STRUCTURE COUR

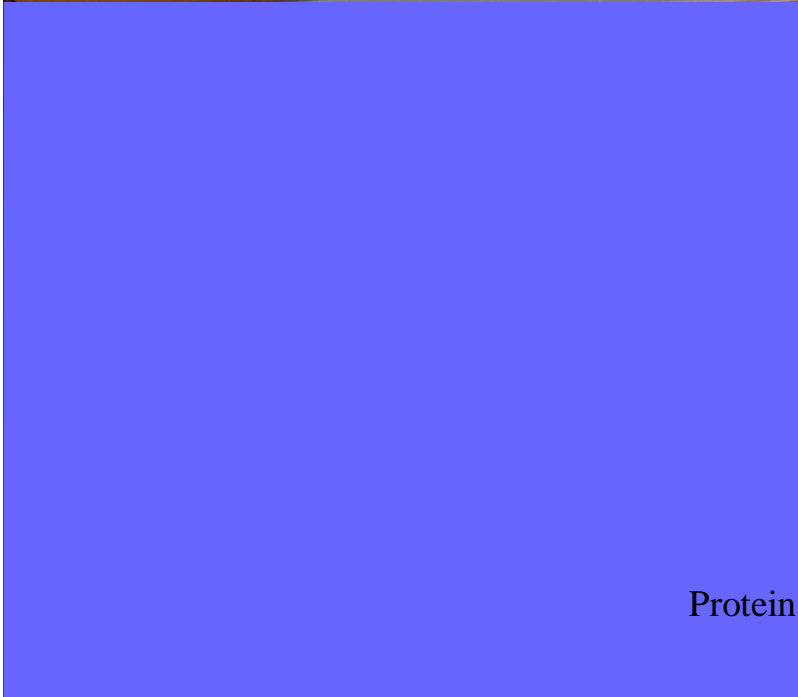
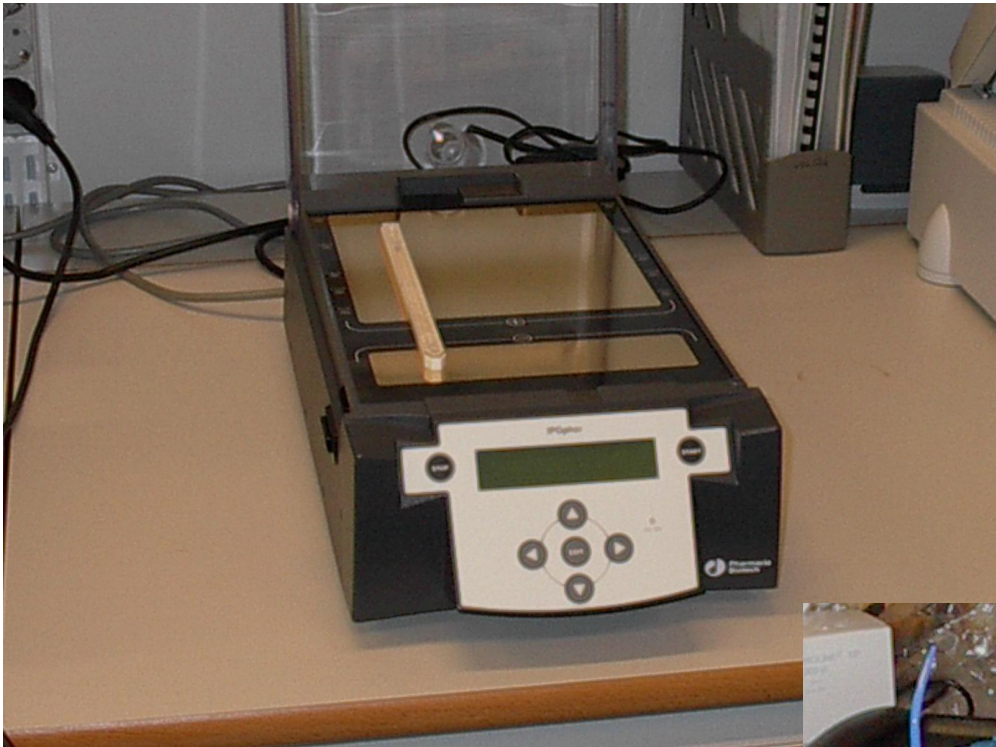

Protein

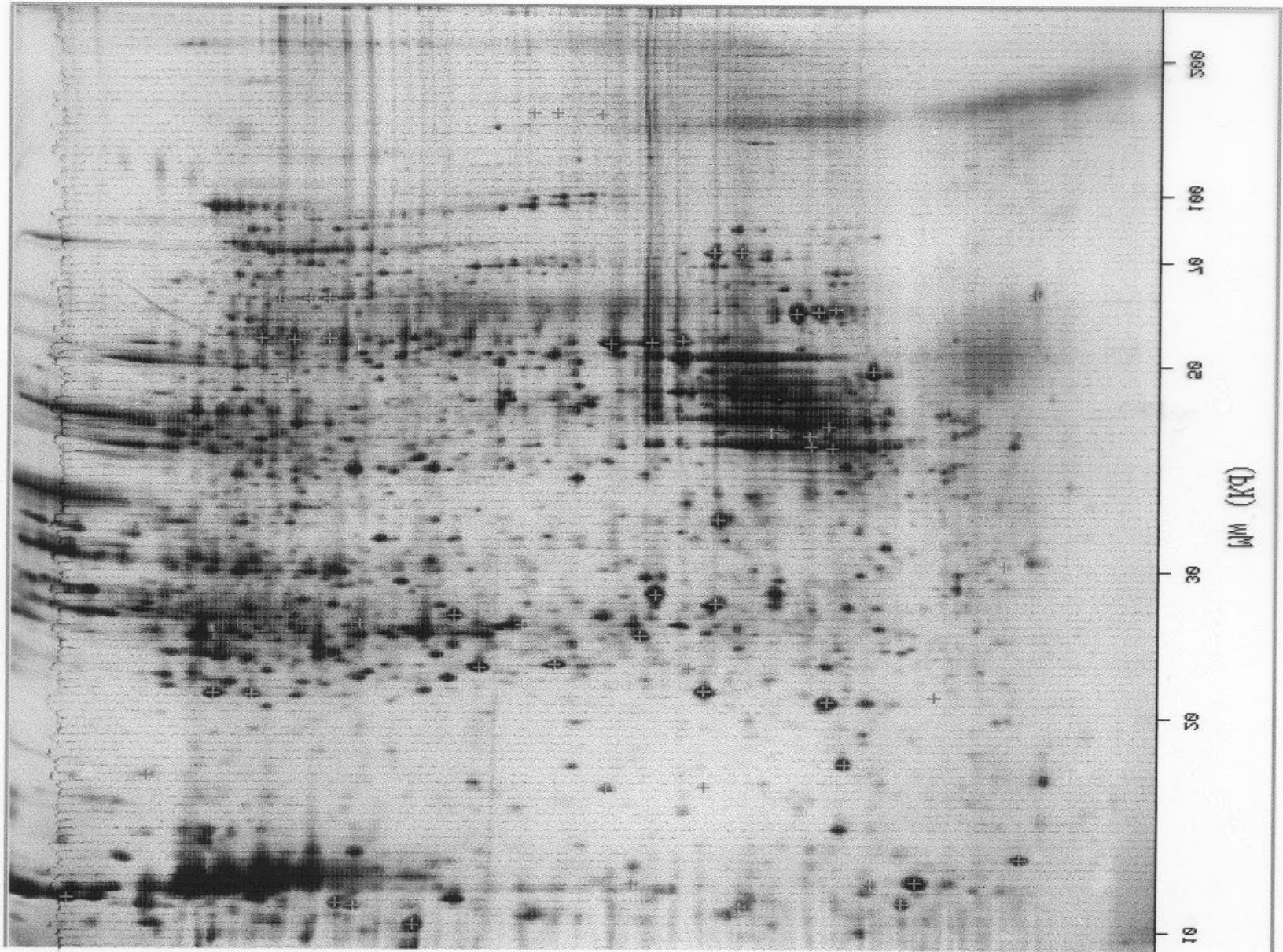

Helsinki 2002

Proteomics Microchips

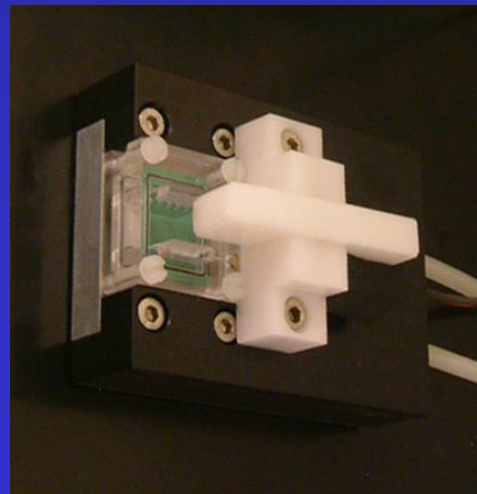
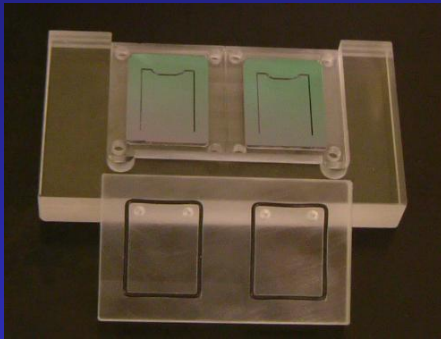
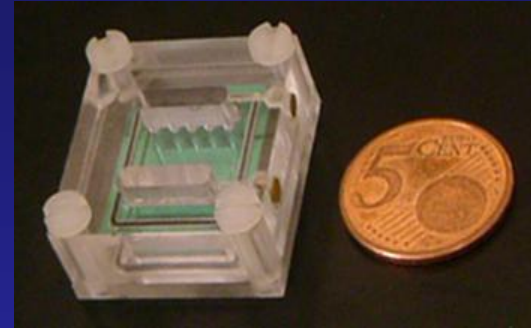
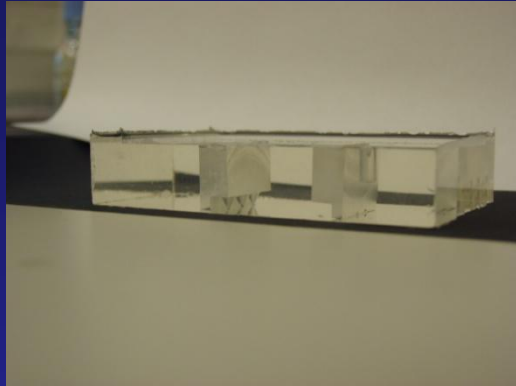

Pump

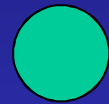

Pump

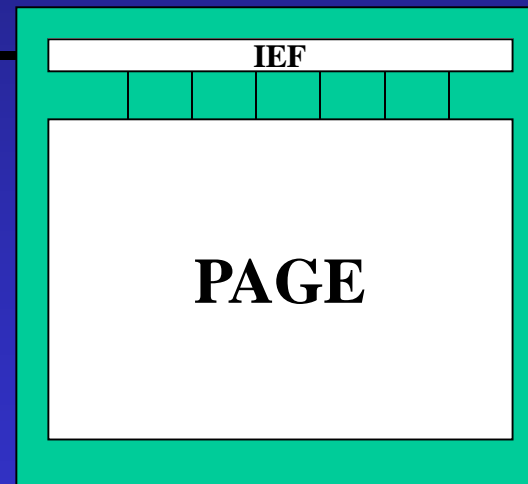
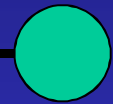

2,4 cm x 2.4 cm

1-D Gel Electrophoresis

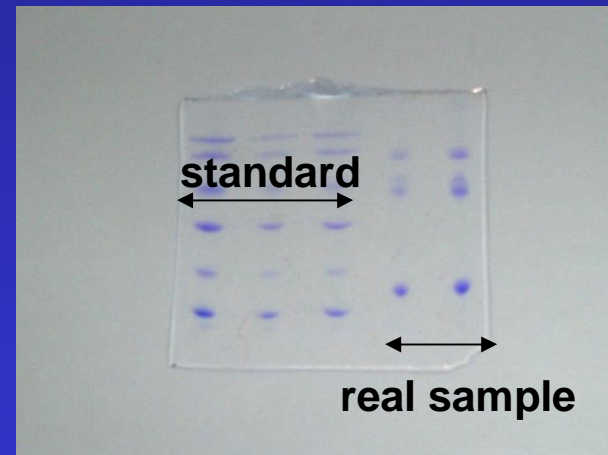
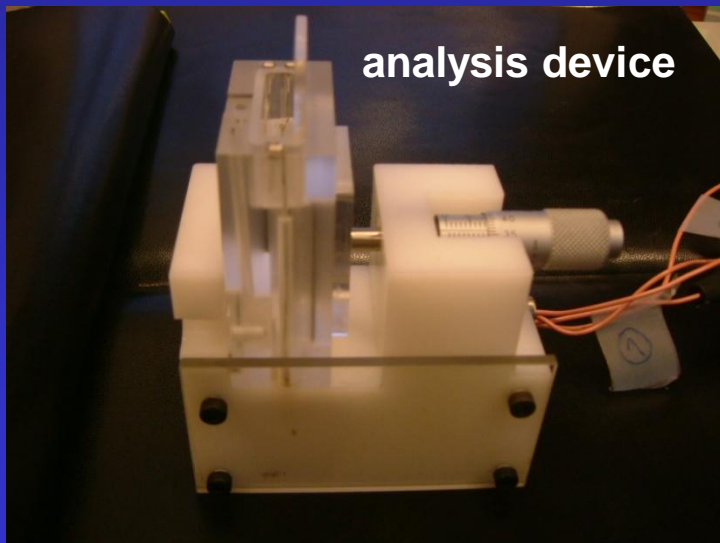
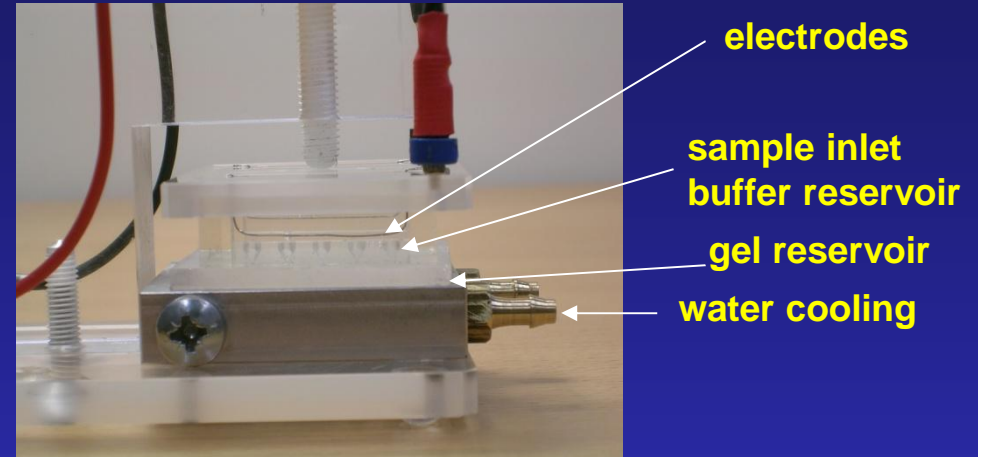
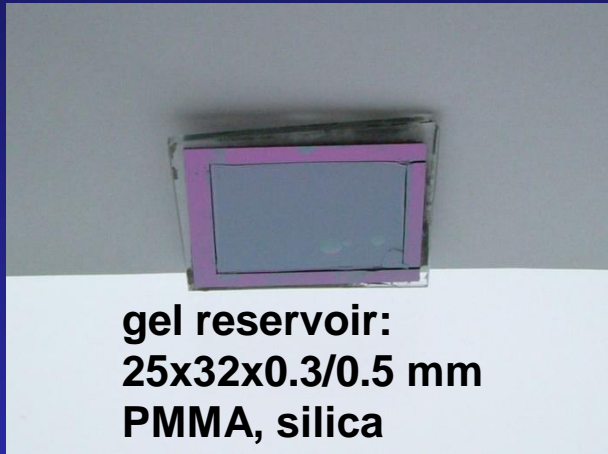

Micro 2-Dimensional PAGE/ Micro 1-Dimensional PAGE

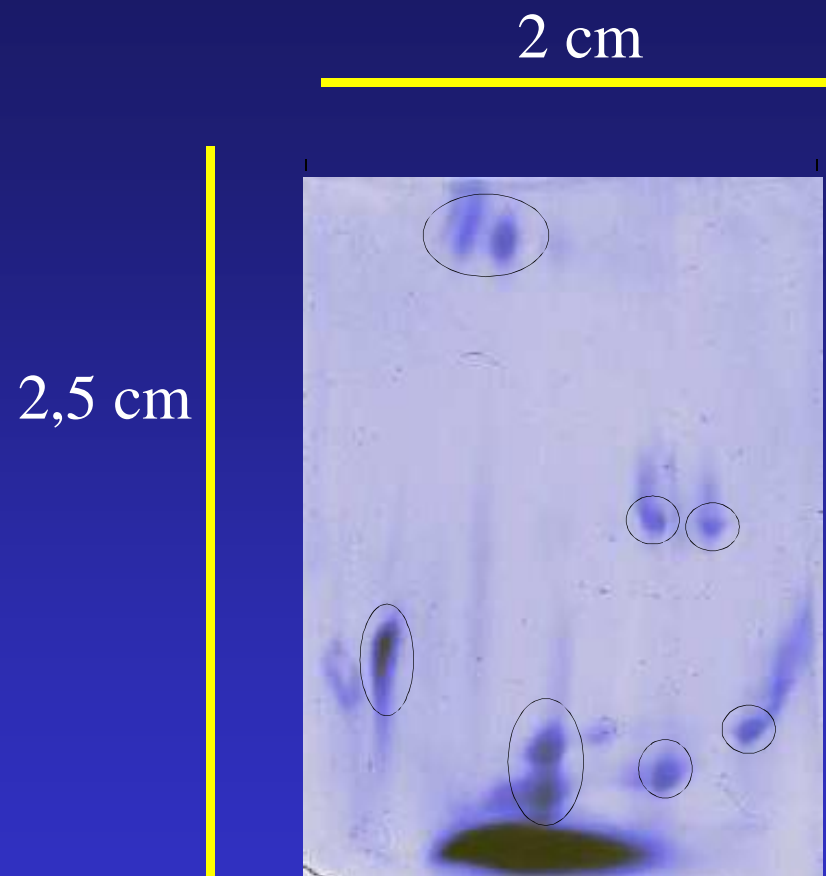

Running time 20-30 minutes

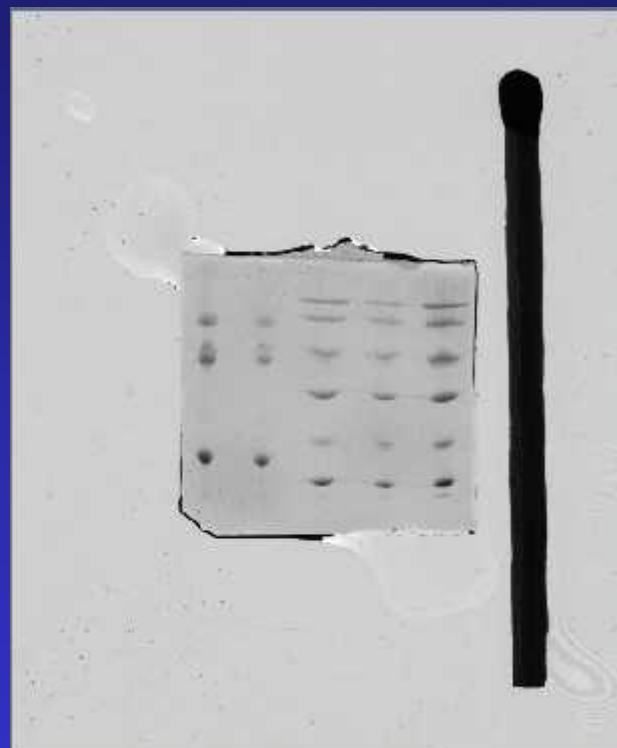

Running time 10 minutes

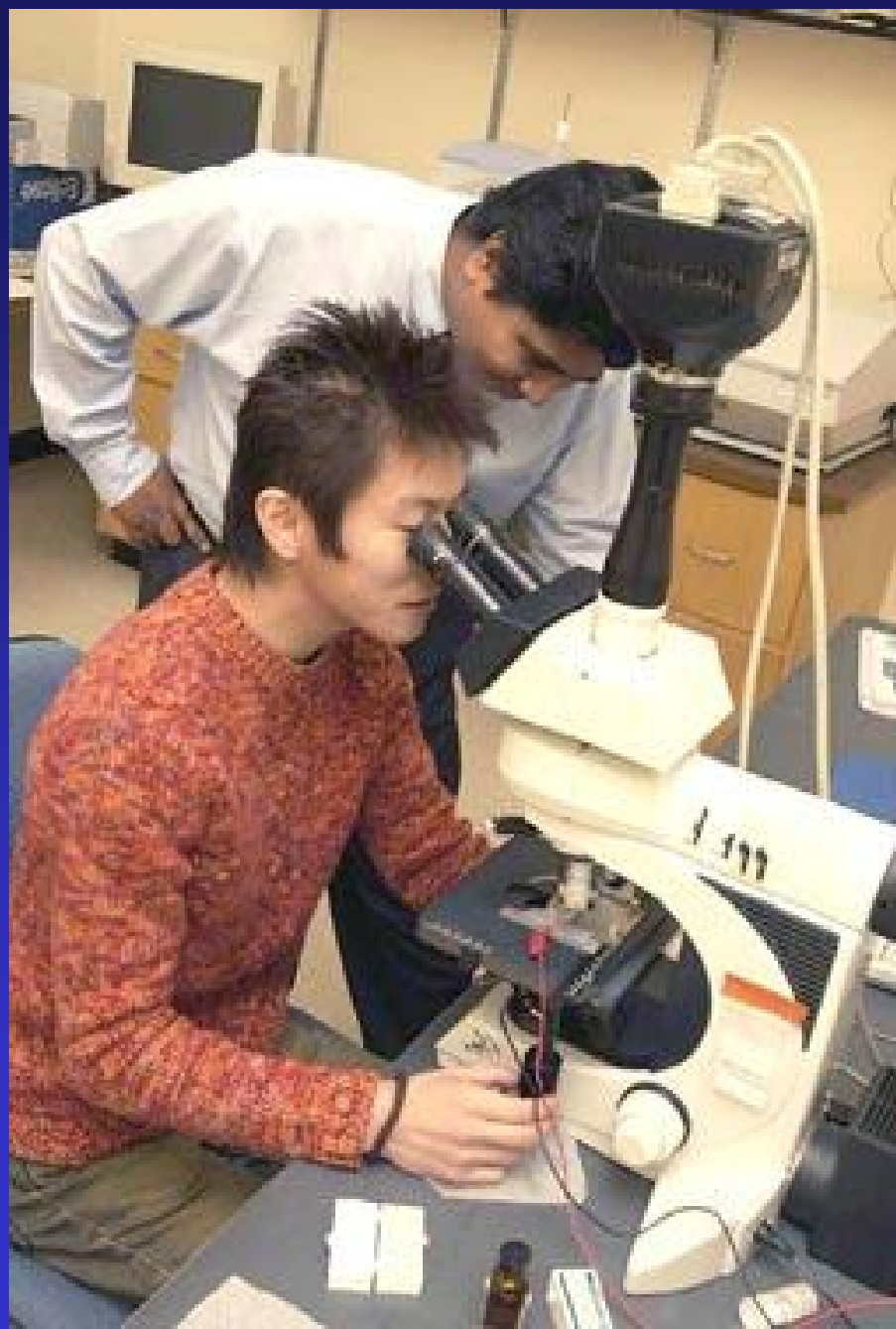

NanoSpray LC/MS (MudPIT)

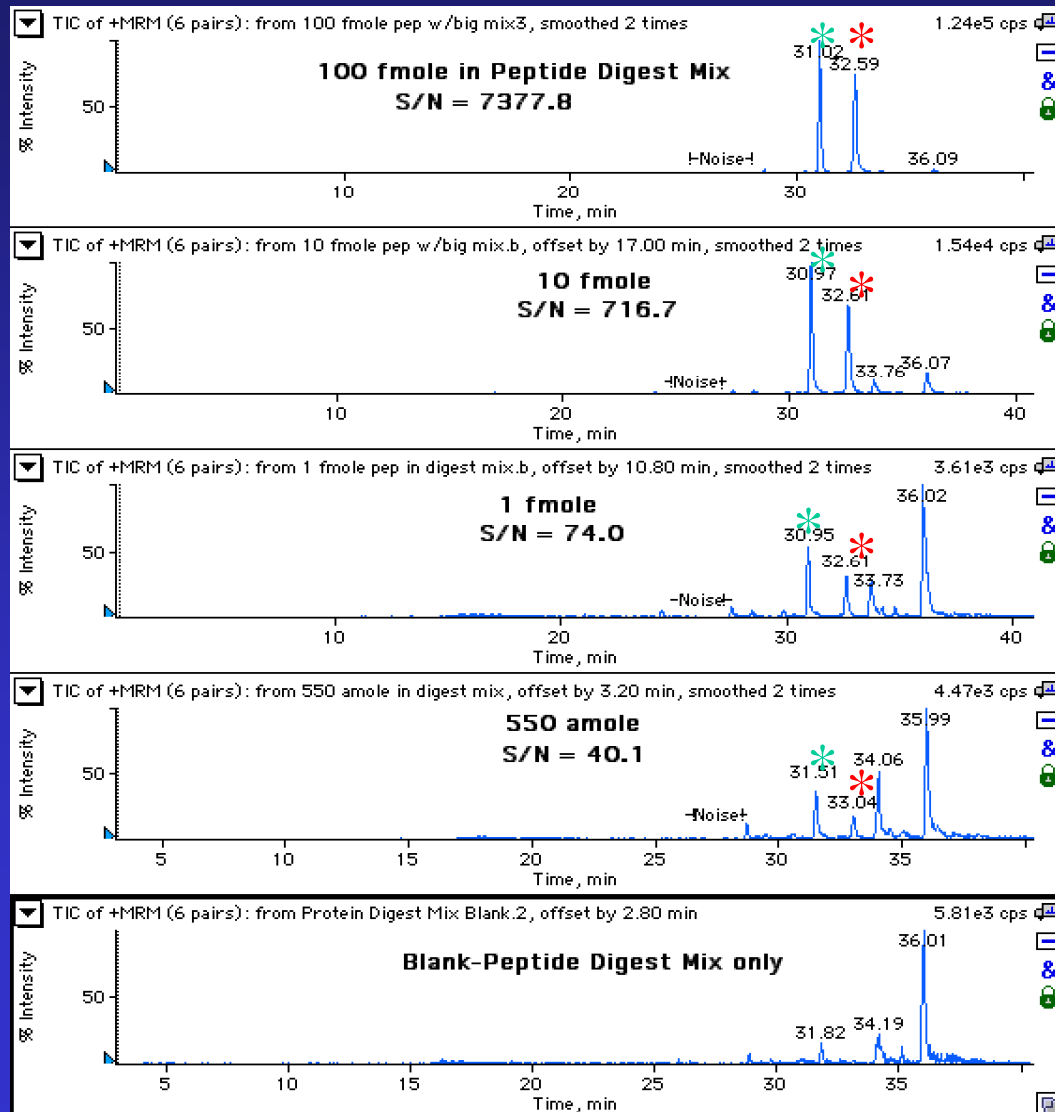

* peptide 1
* peptide 2



Instrumental Set-up SCX/RP/RP (MudPIT)

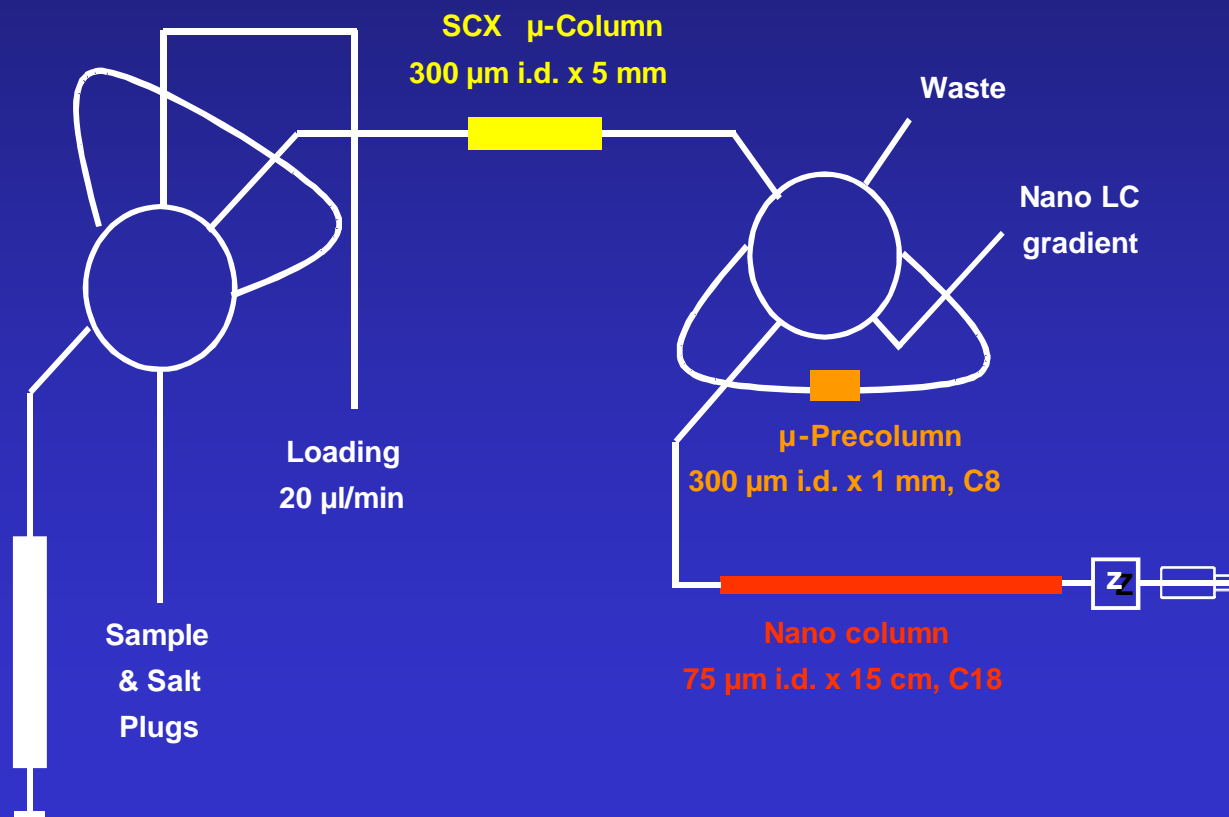

Esquire

NanoSpray LC/MS

TriVersa™ NanoMate® and ESI Chip® System

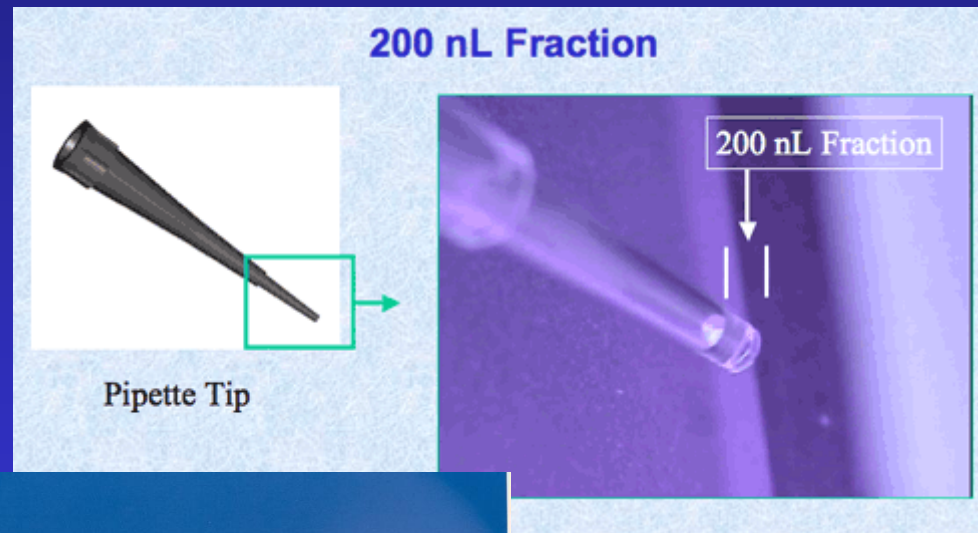
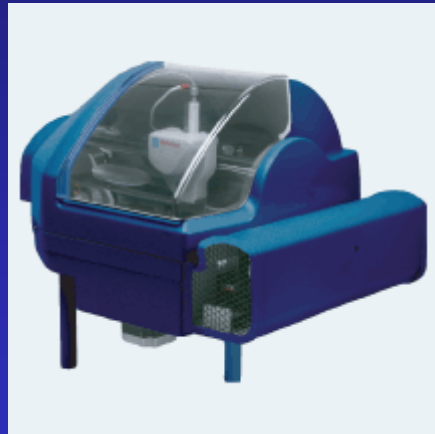

Advion Biosciences

NanoSpray LC/MS

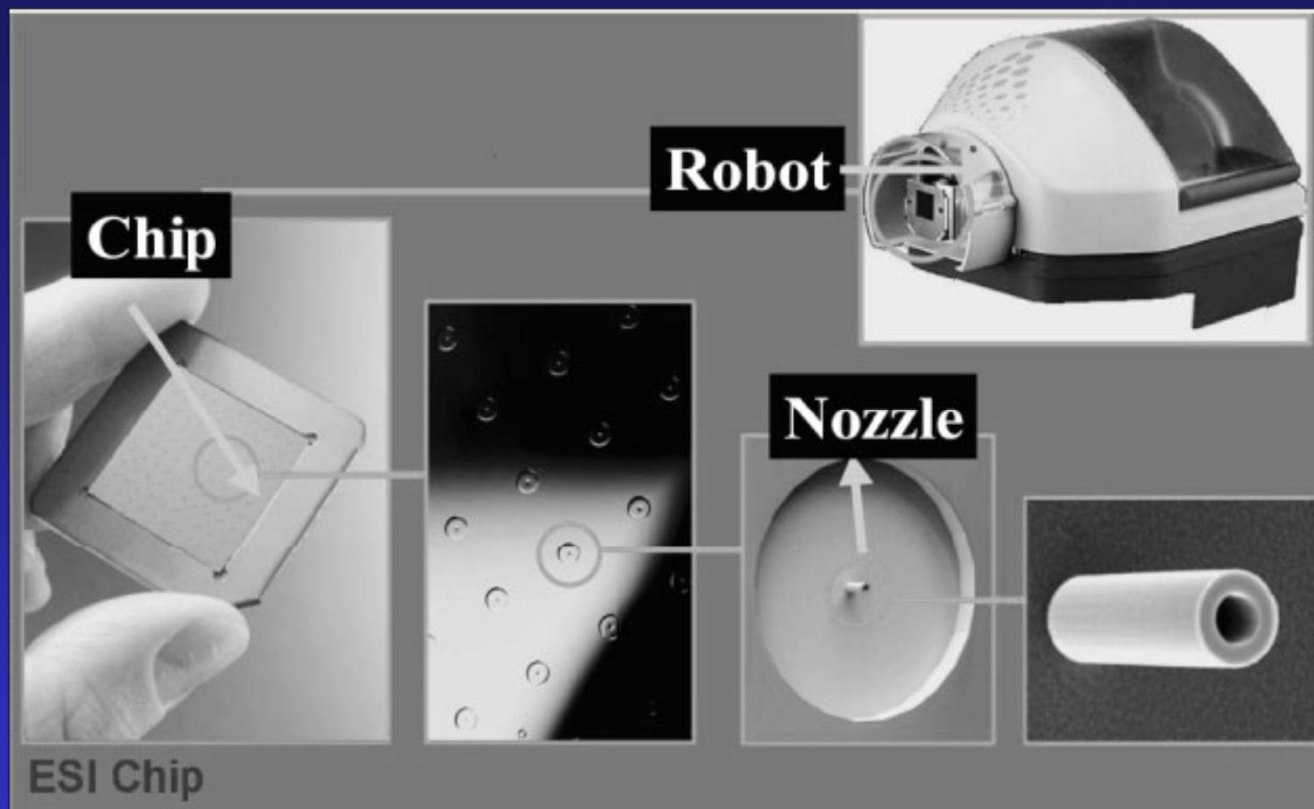

Microarray MS Chip (IonTrap)

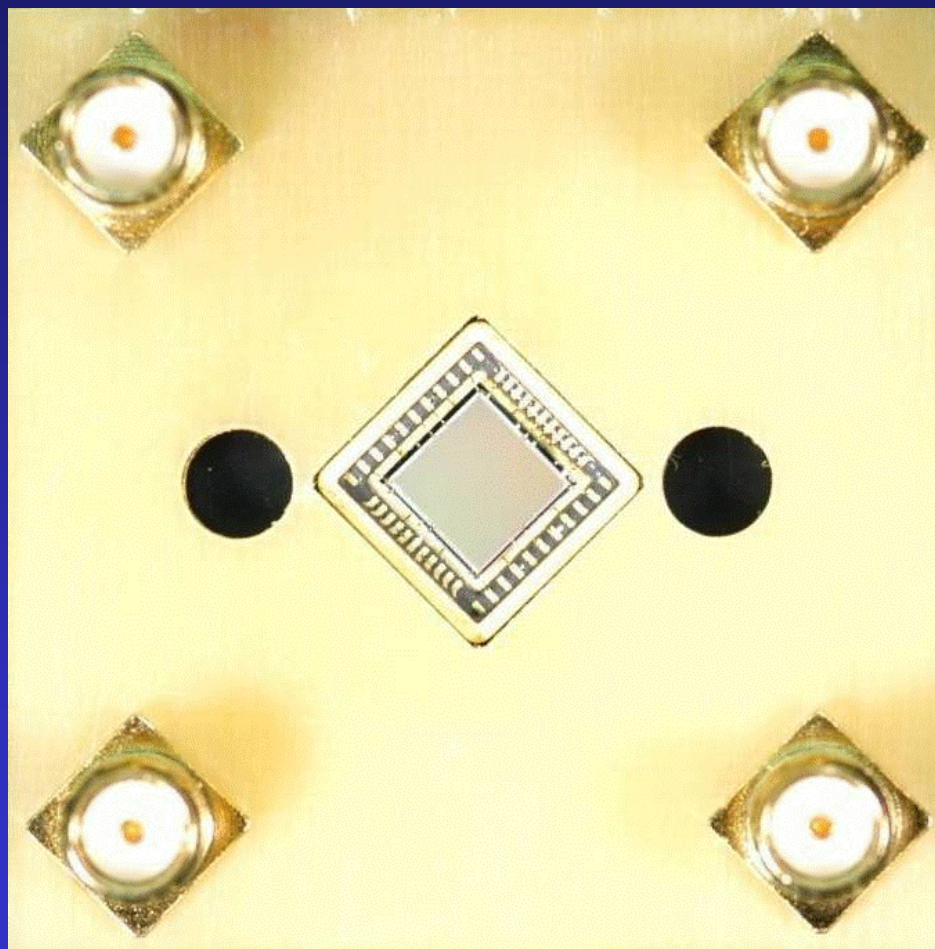

Microarray MS Chip (IonTrap)

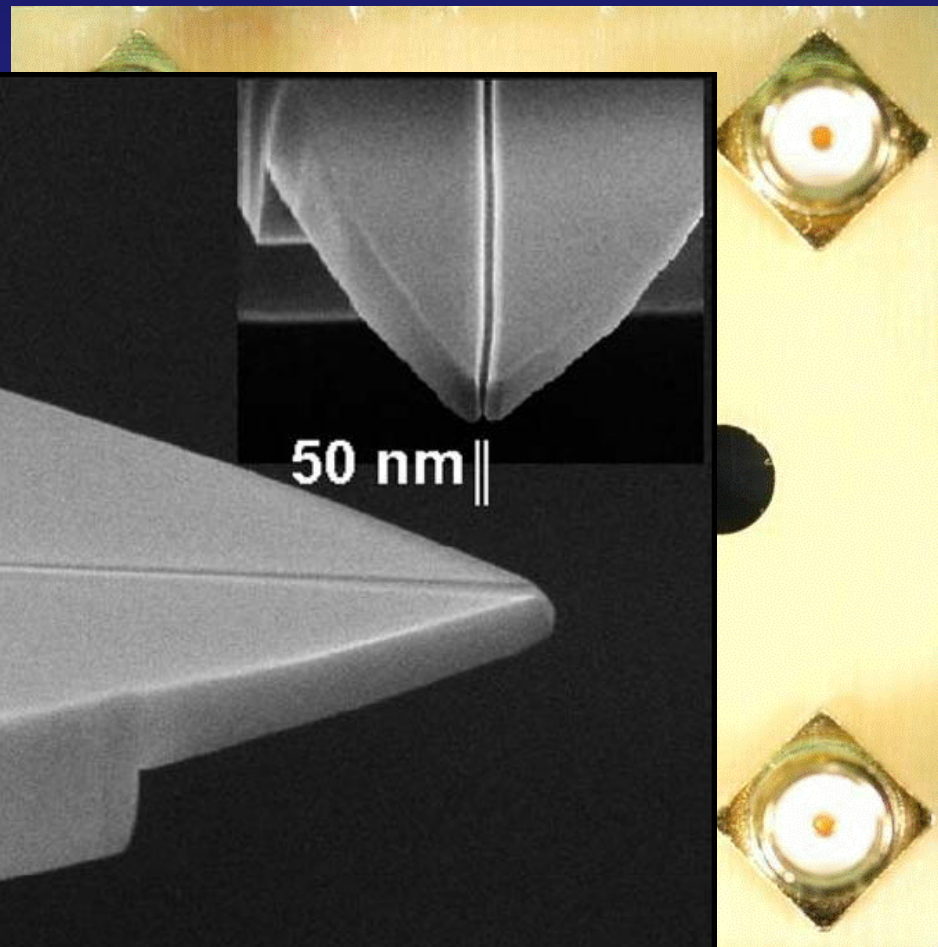
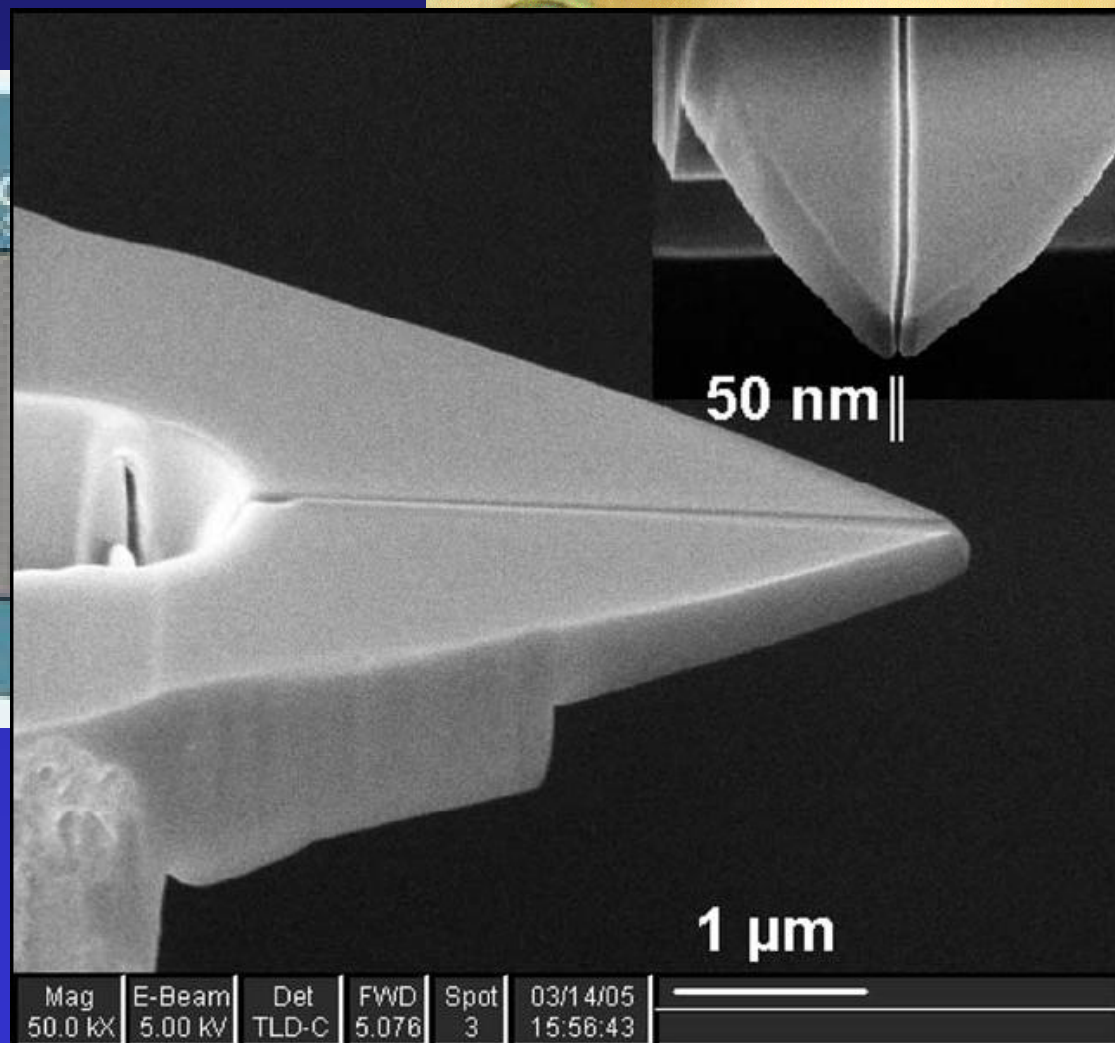

Microarray MS Chip (IonTrap)

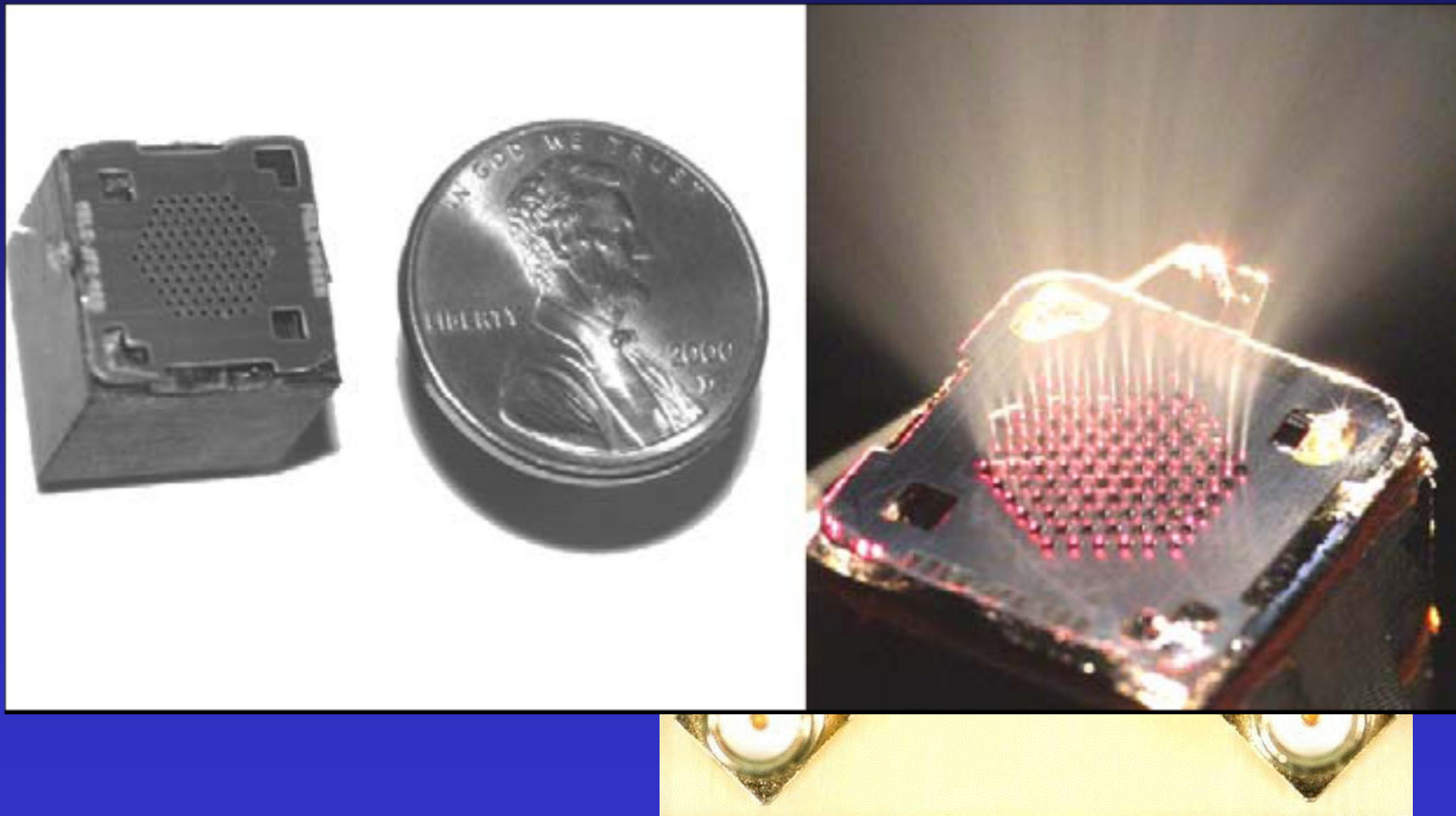

Electroporation on a chip: Cell trapping

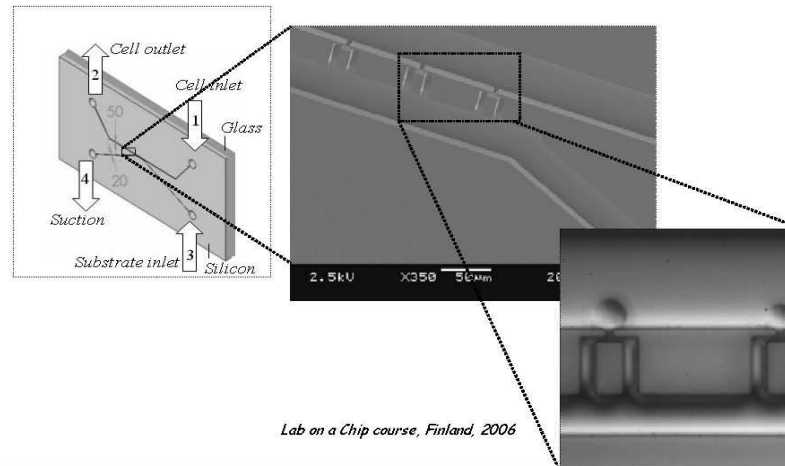

Single cell electroporation

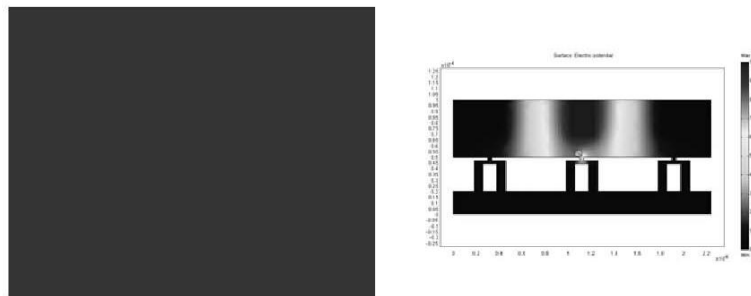

H. Andersson and A. van den Berg, "Microfluidic devices for cellomics: a Review", *Sensors and Actuators B*, **92** (3), (2003), 315-325.

Lab on a Chip course, Finland, 2006

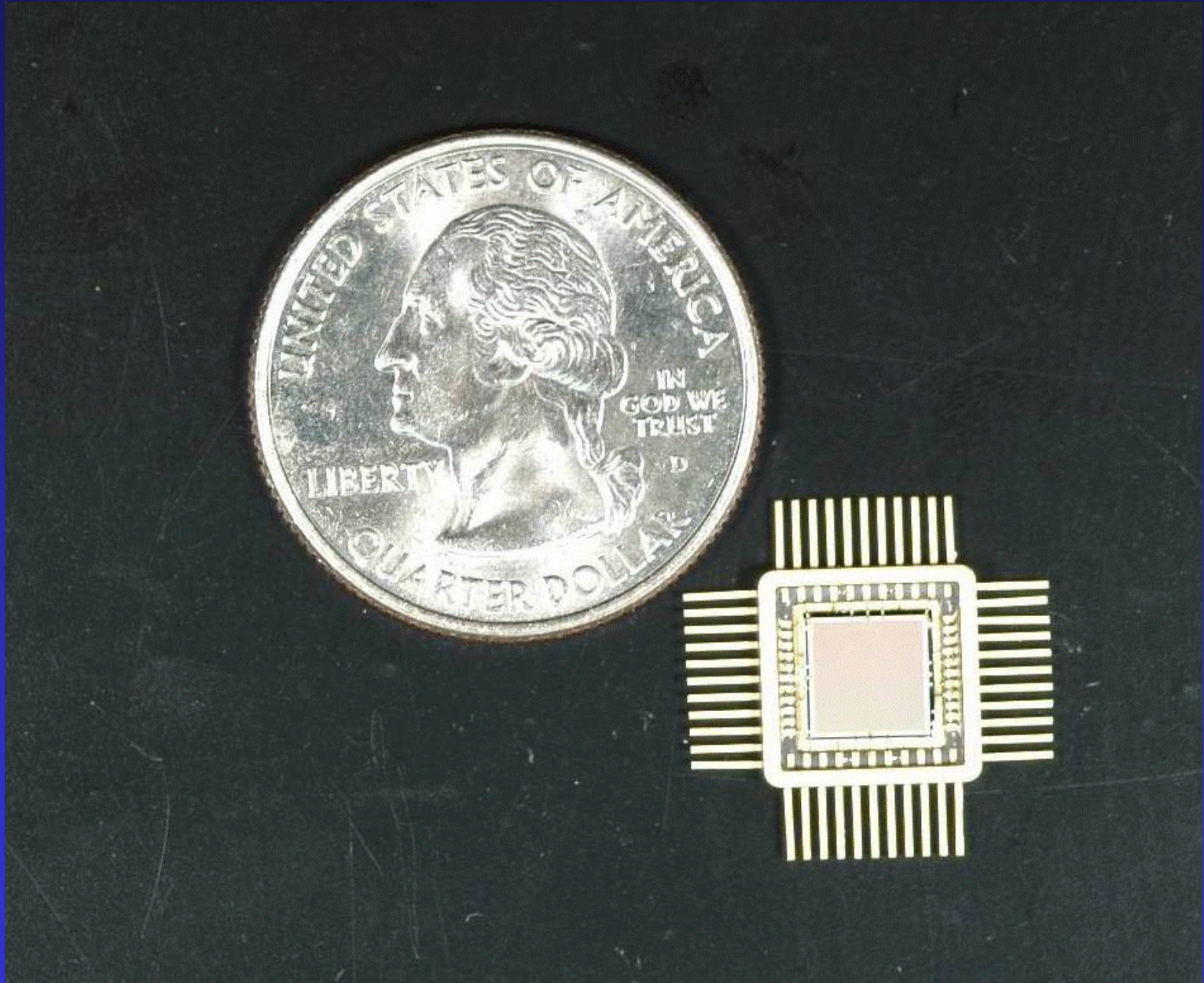

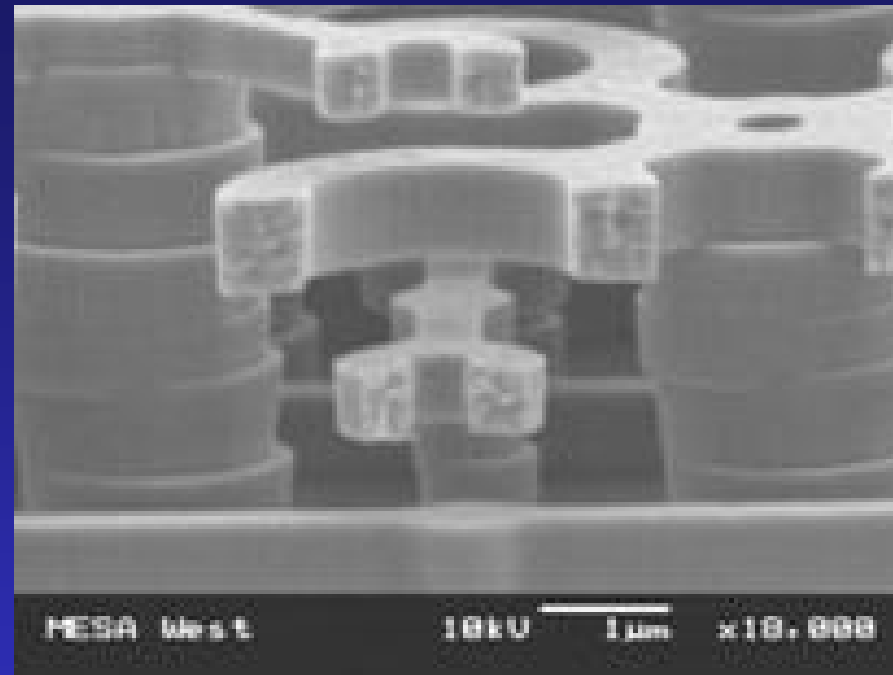
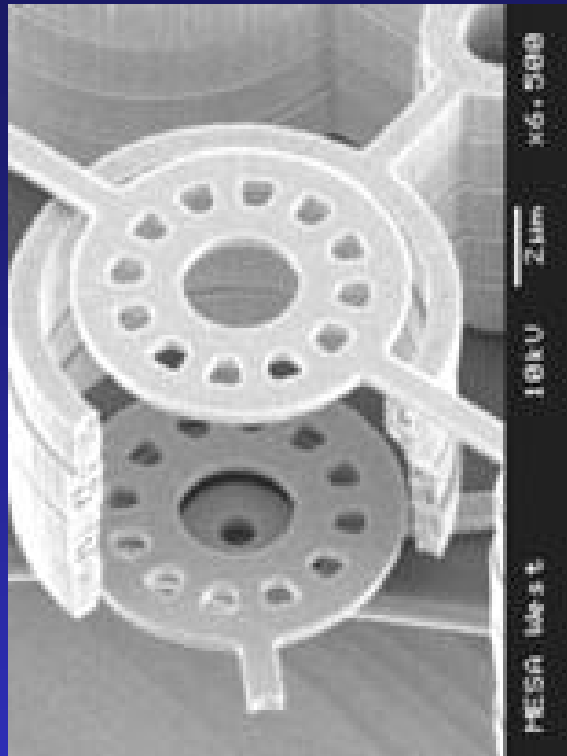

A set of thousands of Mass Spectrometers in one chip

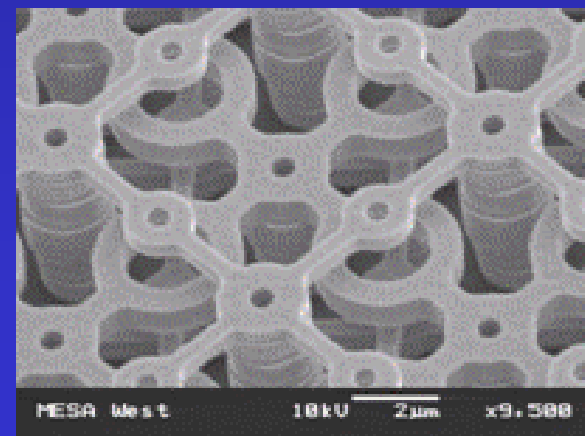

On-Line MALDI Protein Microarray

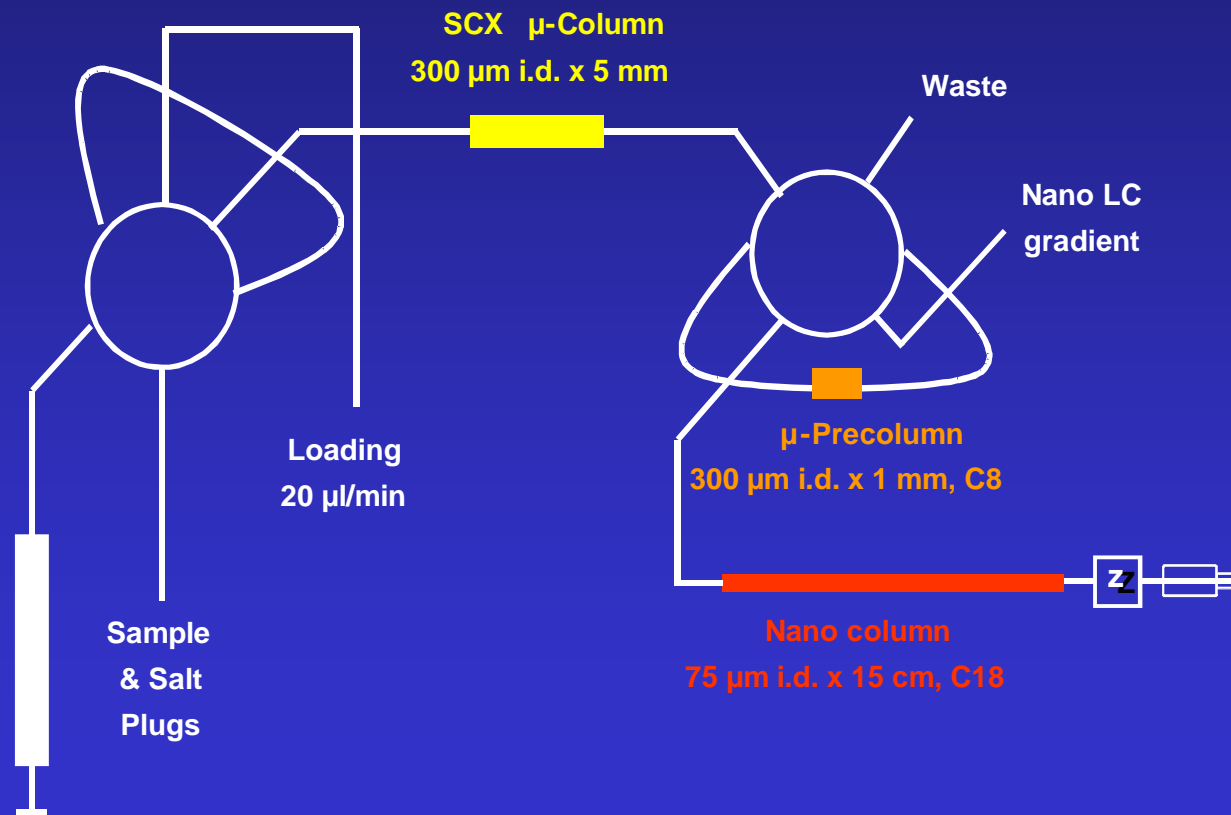

Automated Micro-Chip Robot loader

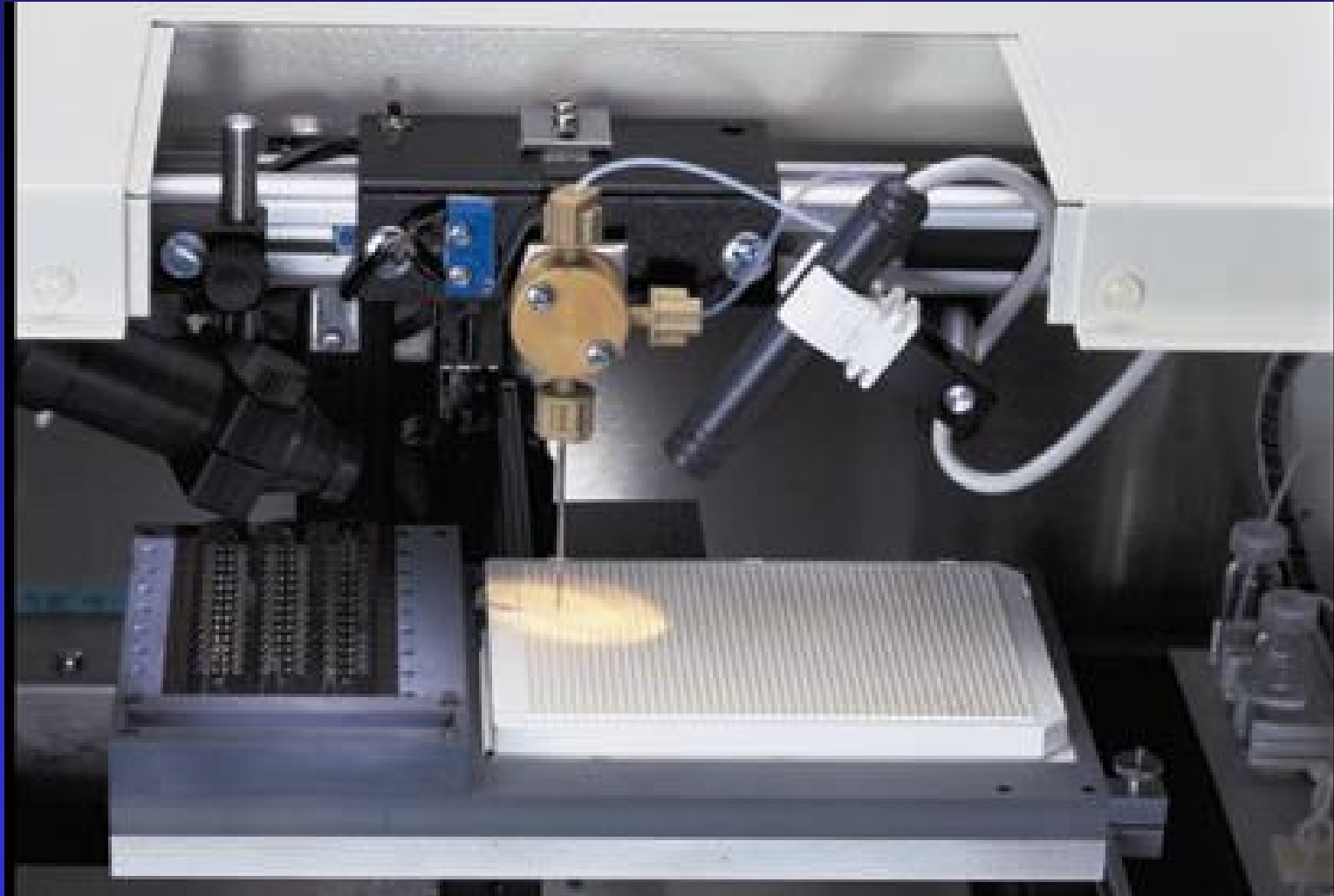

**High sample throughput for the
Post-Genomic Era**



MALDI-TOF-MS



What else can we do?

SELDI = Chip based surface enhanced laser desorption analysis

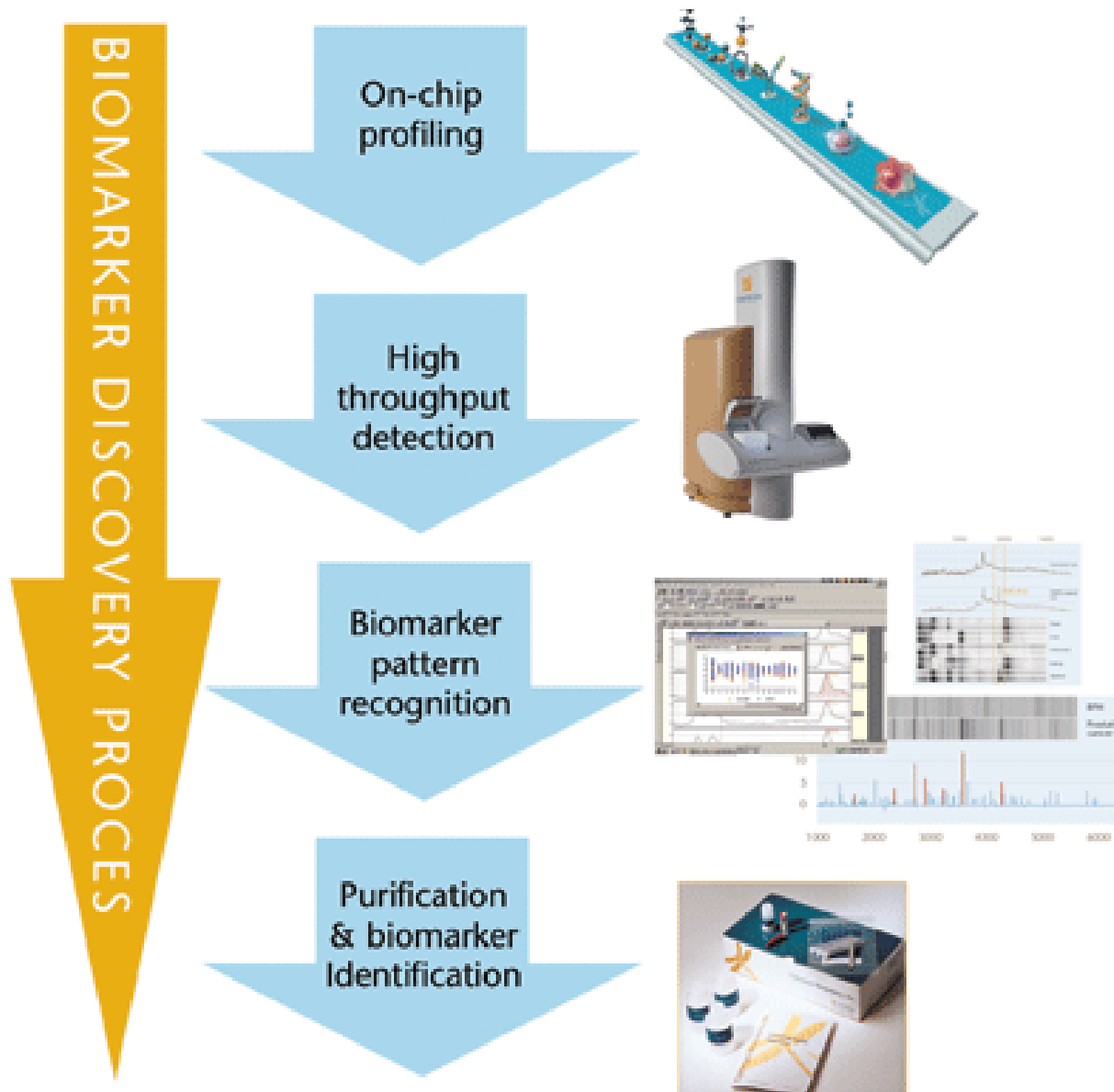

Discover, validate & identify predictive protein biomarker panels

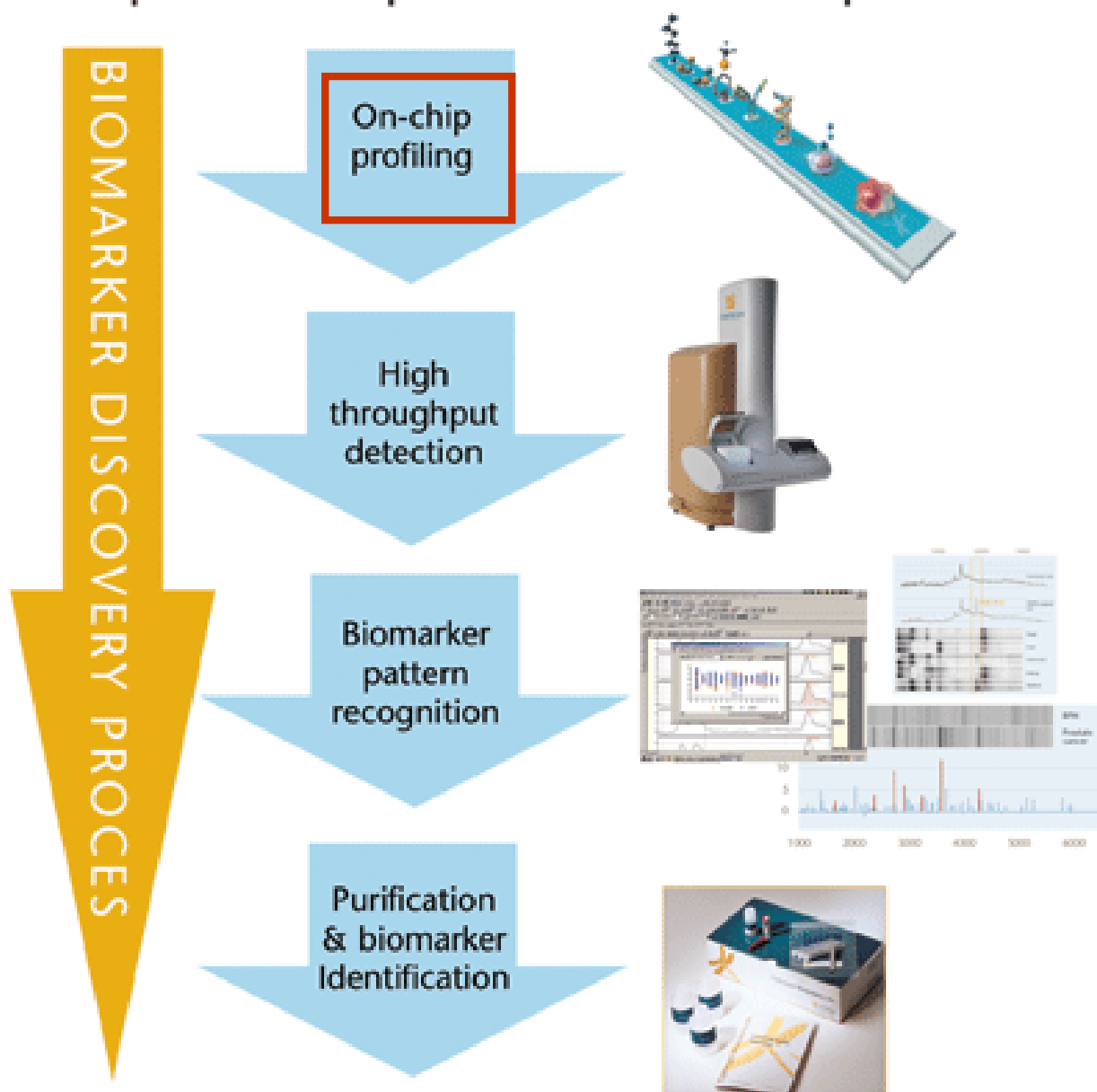

The Chip

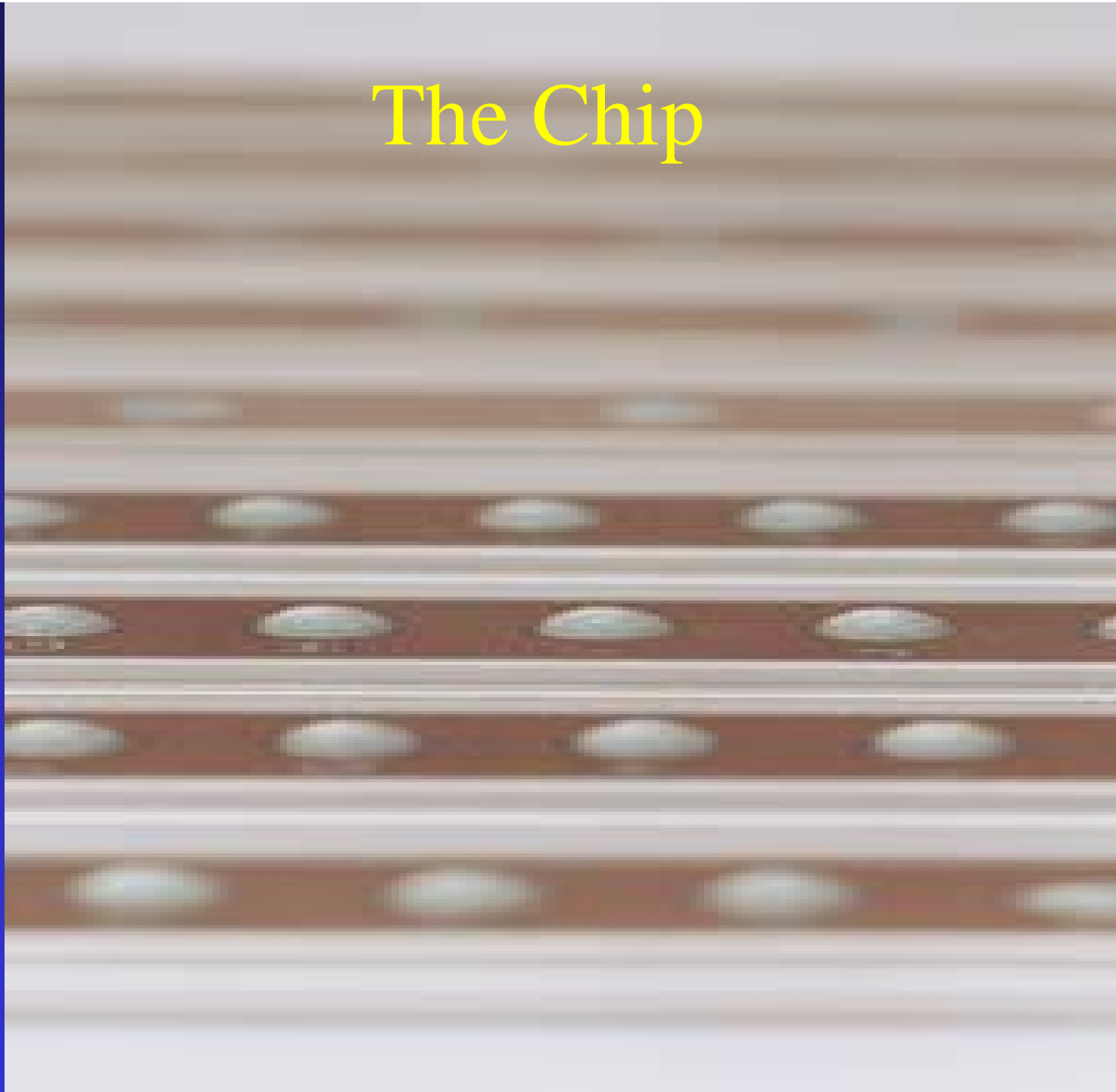

Ciphergen ProteinChip® Array Surfaces

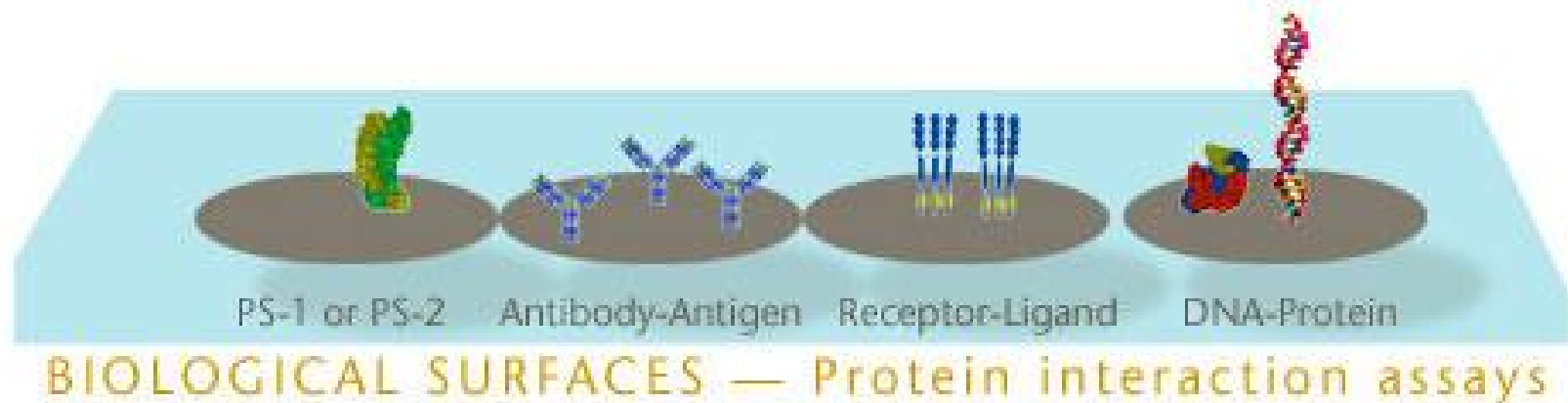
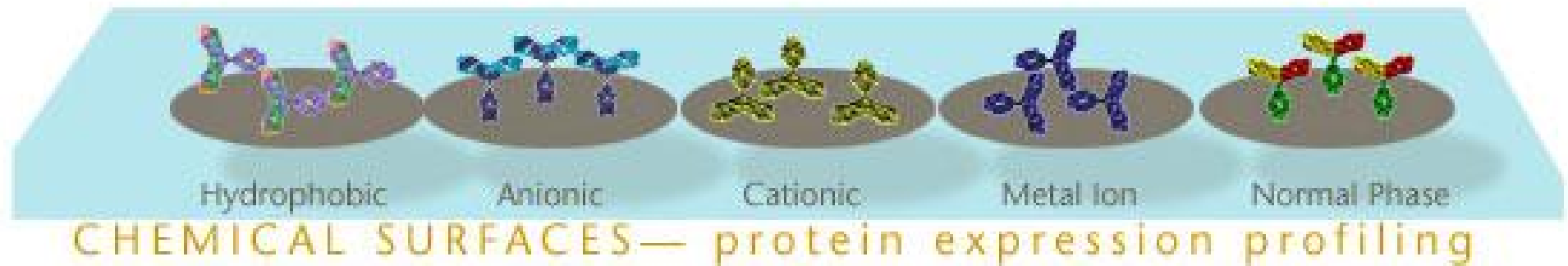

1. Apply Crude Sample

Proteins bind to chemical or biological "docking sites" on the ProteinChip Array surface through an affinity interaction.

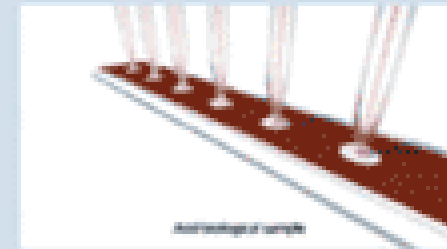

2. Wash ProteinChip Array

Proteins that bind non-specifically and buffer contaminants are washed away, eliminating sample "noise."

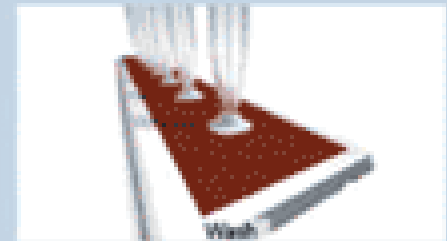

3. Add Energy Absorbing Molecules

After sample processing, the ProteinChip Array is dried and EAM is applied to each spot to facilitate desorption and ionization by SELDI-TOF-MS.



4. Analyze in a ProteinChip Reader

The proteins that are retained on the ProteinChip Array are detected in the ProteinChip Reader.



SELDI-TOF MS Retentate Chromatography

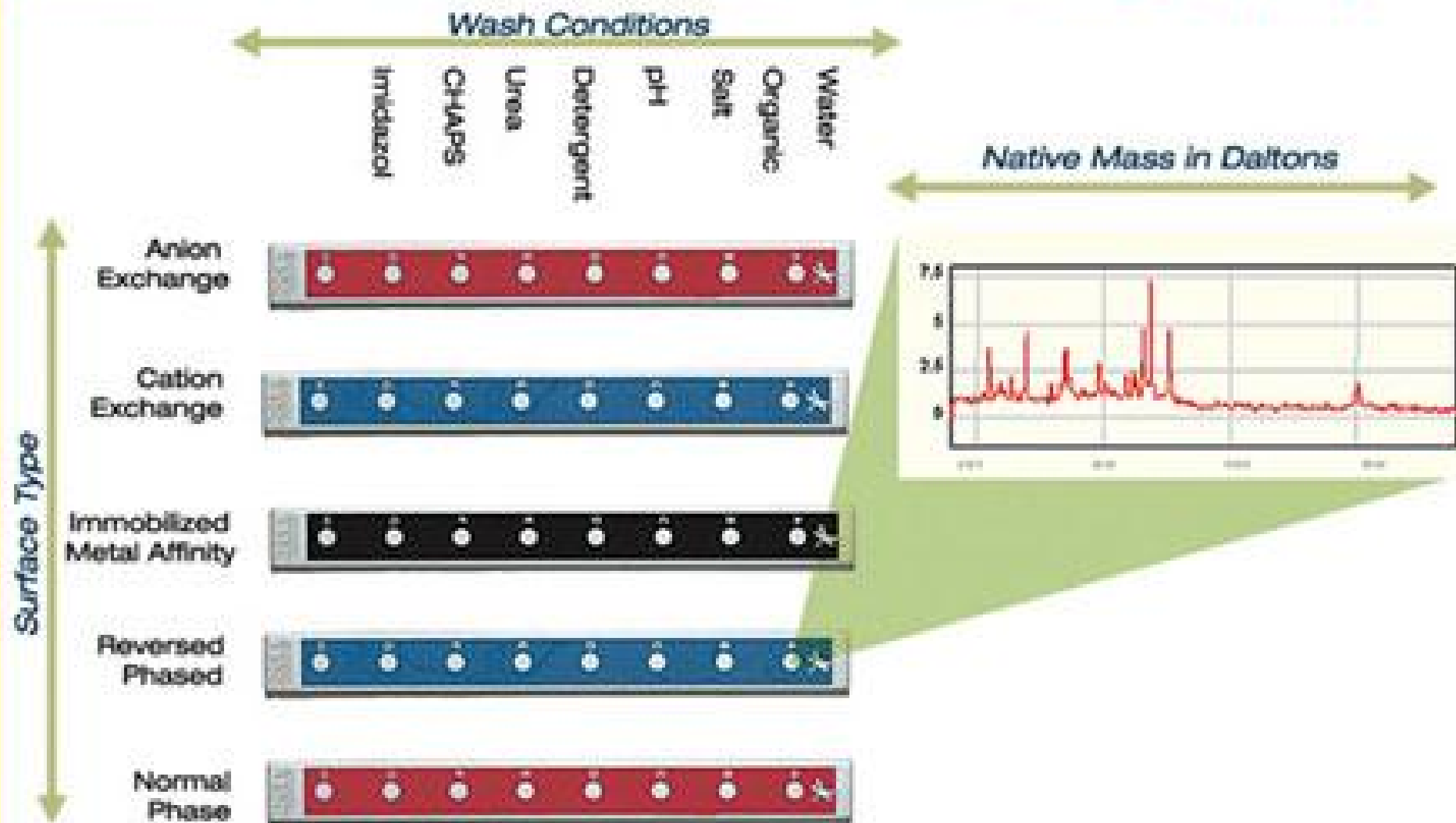

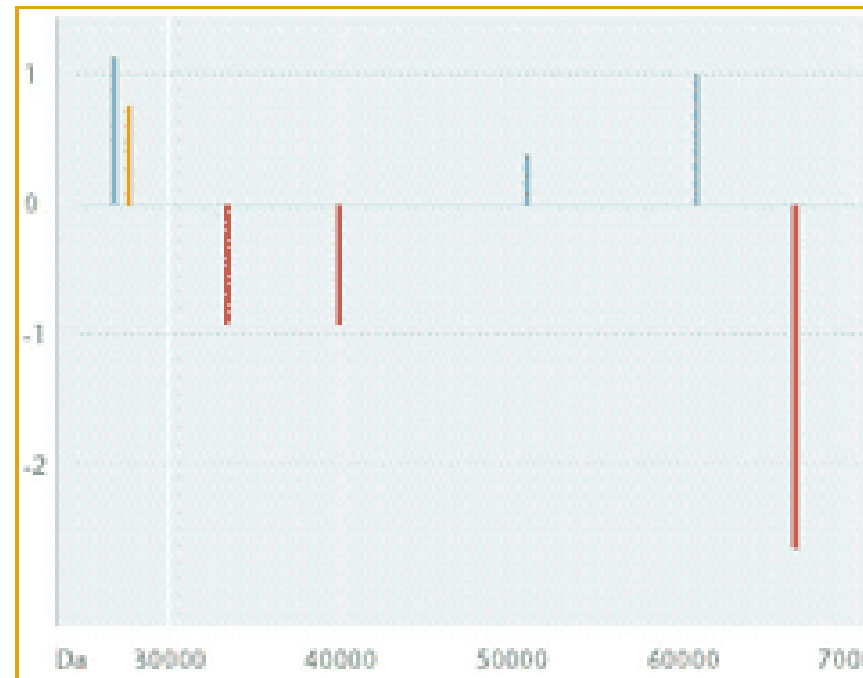
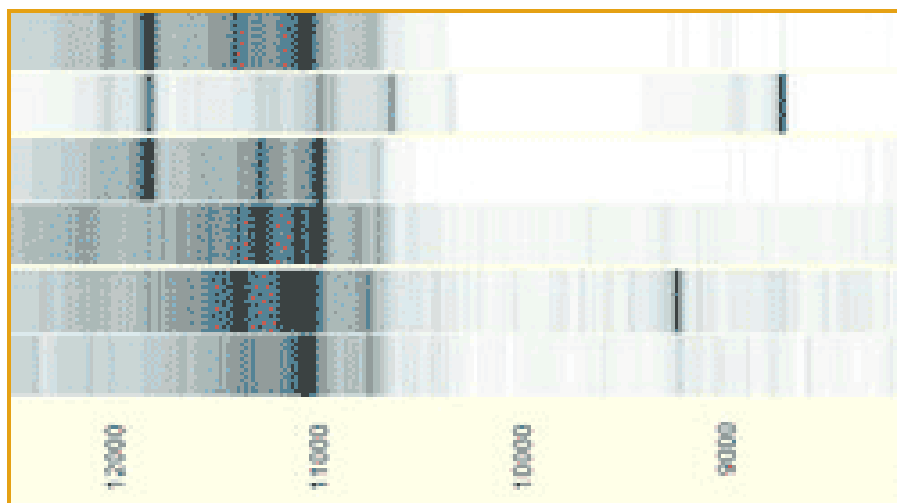
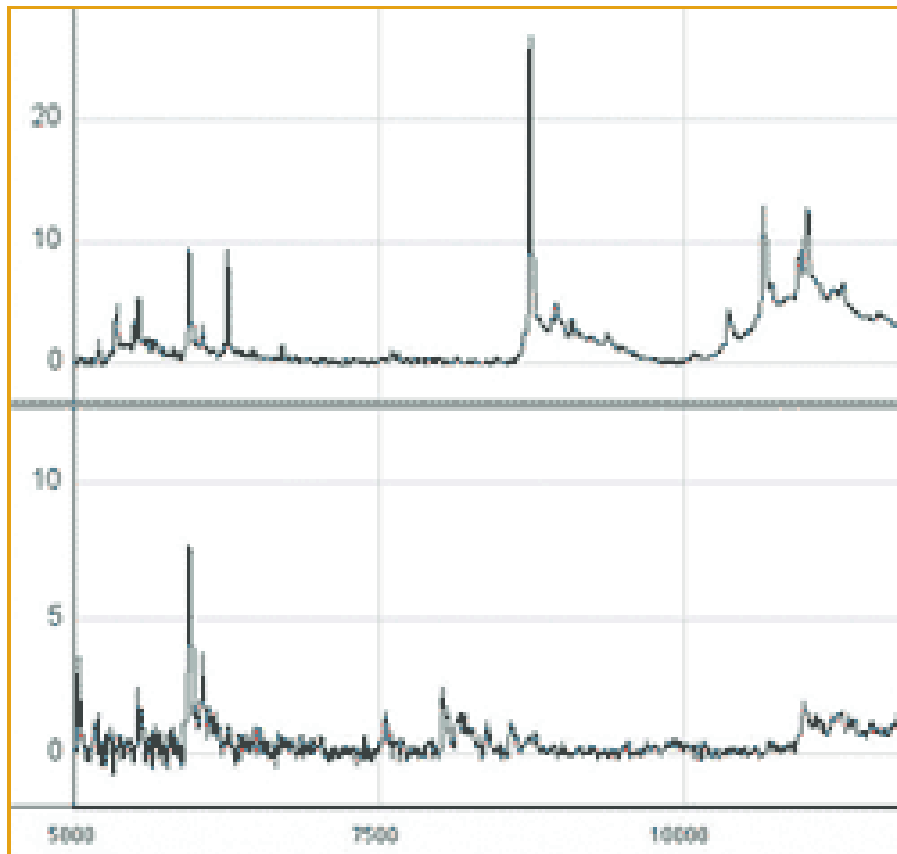

Data Views

The ProteinChip Software automates biomarker analysis and provides a choice of views for easy data interpretation.

The basic **Trace View** displays SELDI protein profiles. The horizontal axis indicates molecular weight; the vertical axis indicates abundance.

The **Gel View** translates profiles to simulate gel lane images for easy viewing and interpretation.

The **Peak Map View** displays differential protein expression.

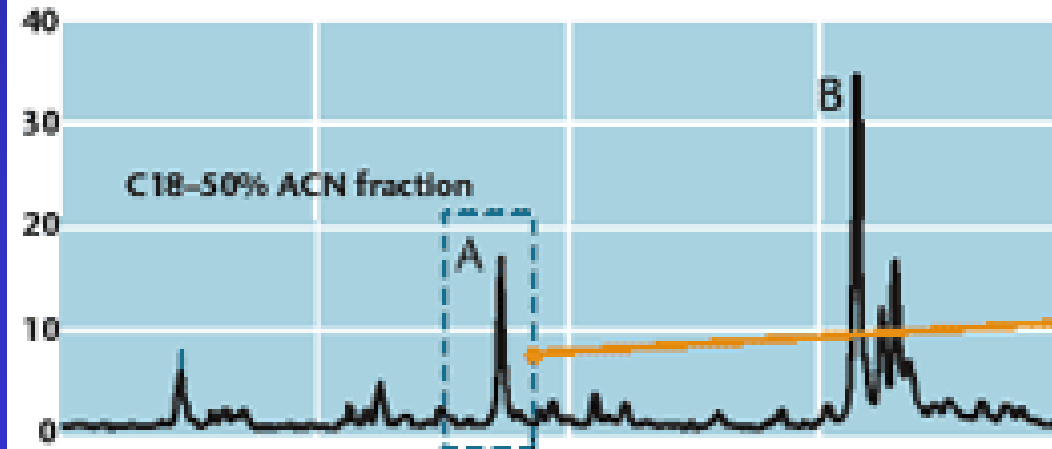
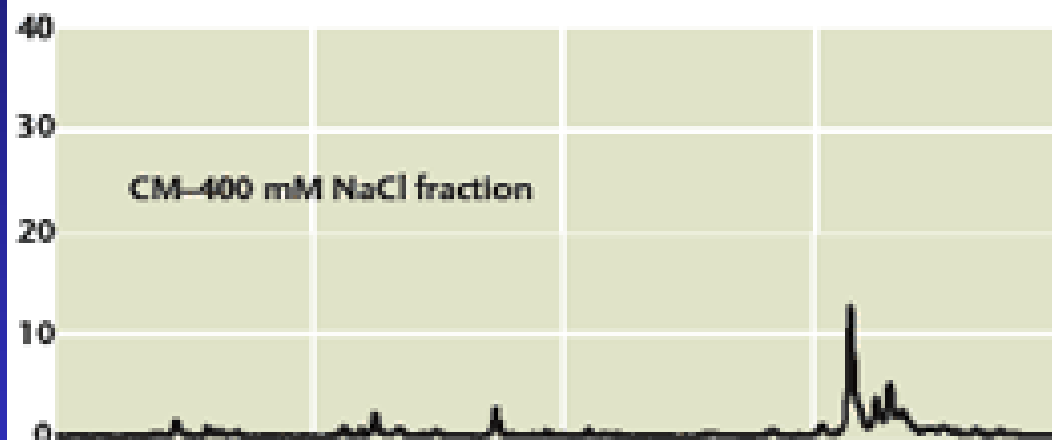
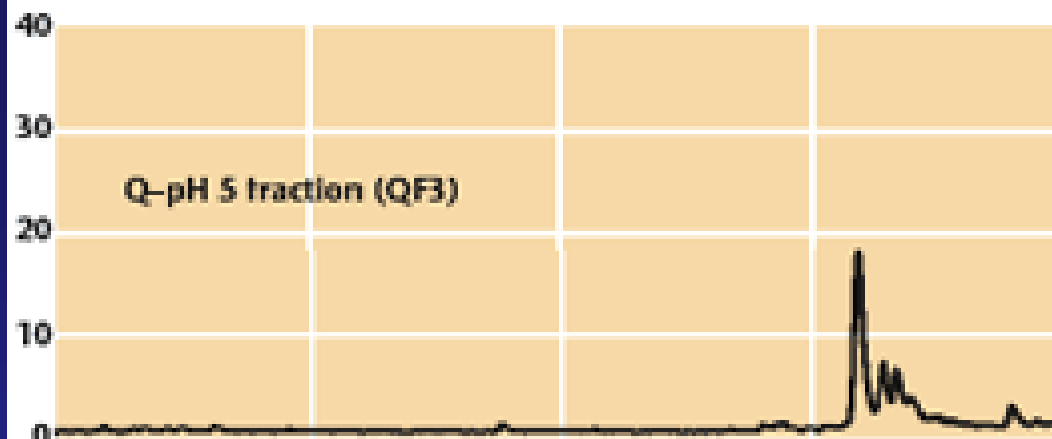



Schematic of ProteinChip Reader

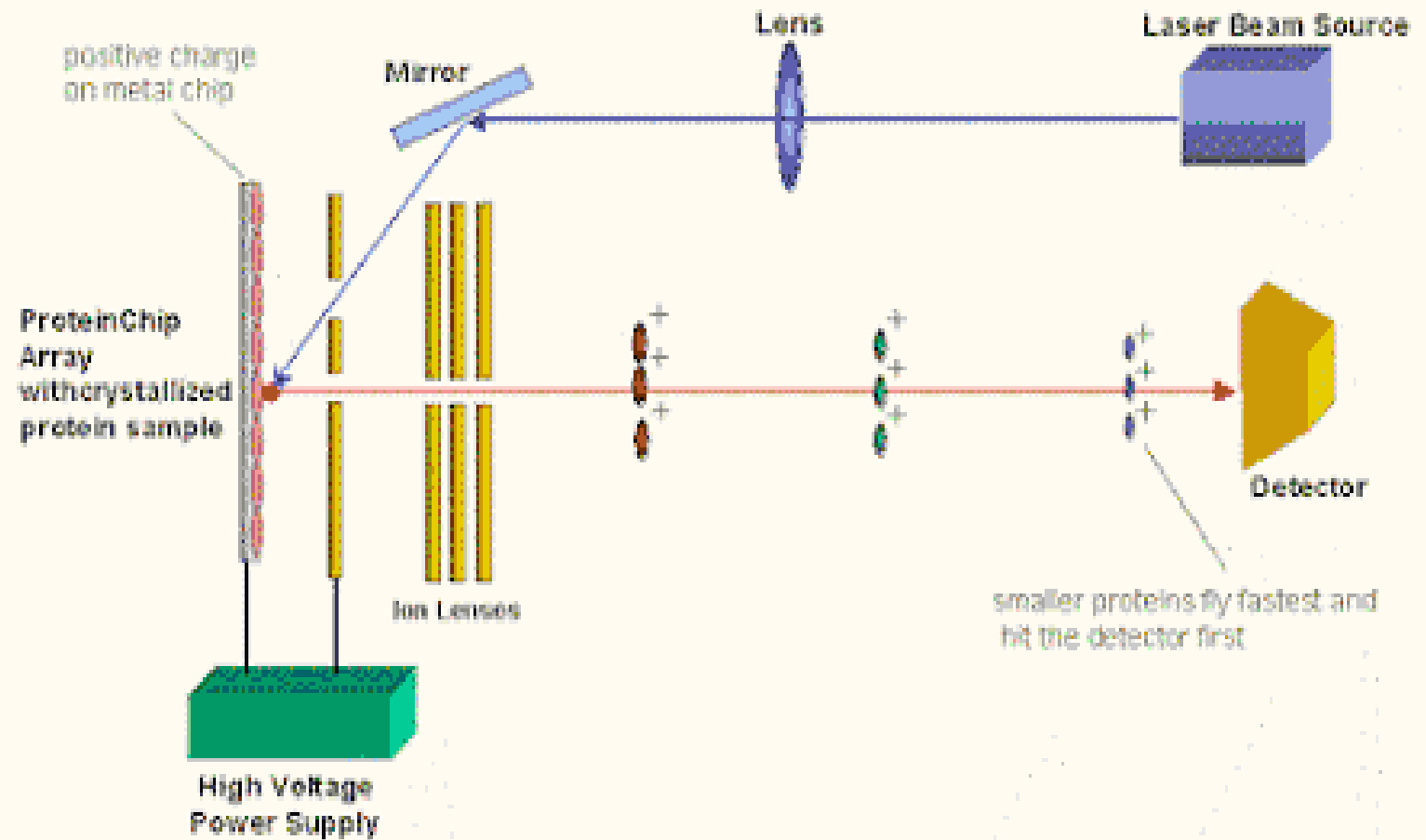

Current Developments In SELDI Affinity Technology Mass Spectrometry Reviews, 23, 34-44, (2004)

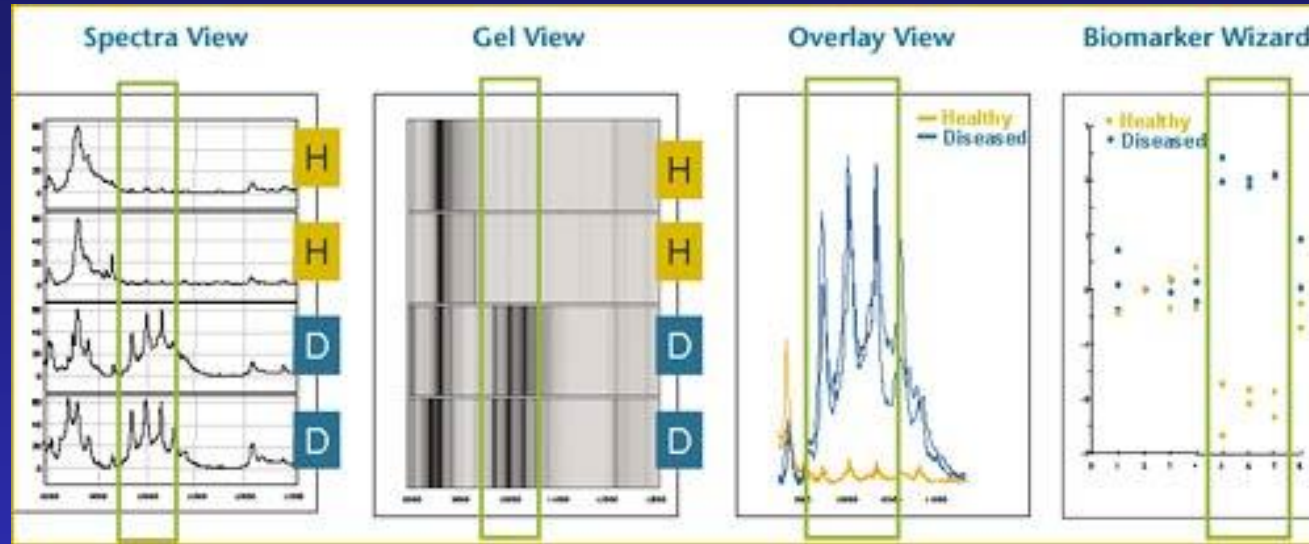

High Throughput

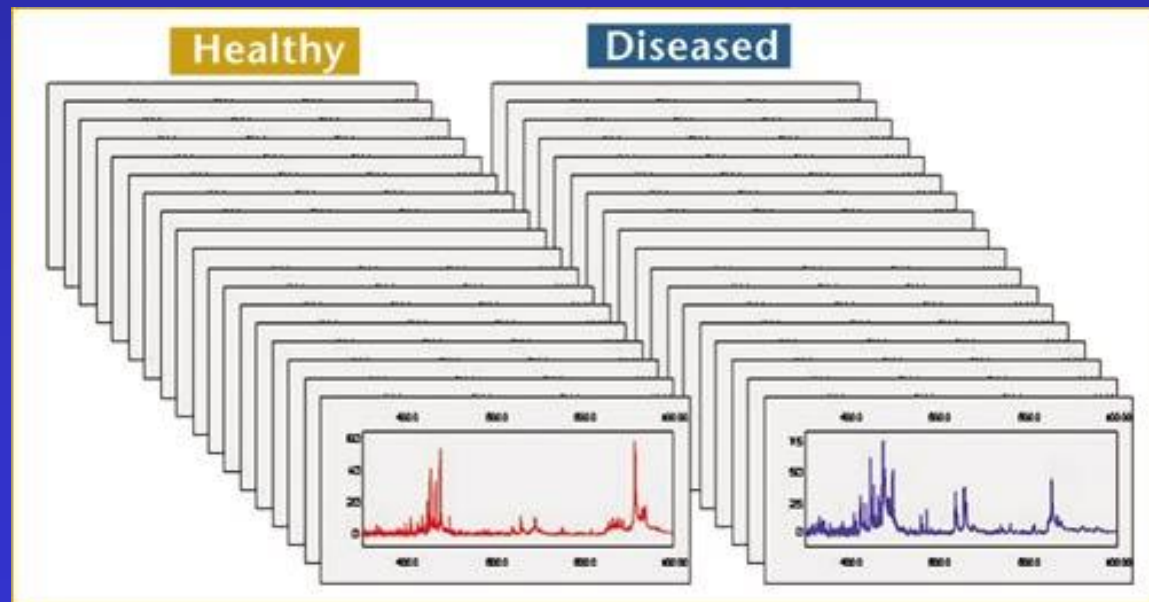

Unraveling biological pathways using the Interaction Discovery Mapping™ platform

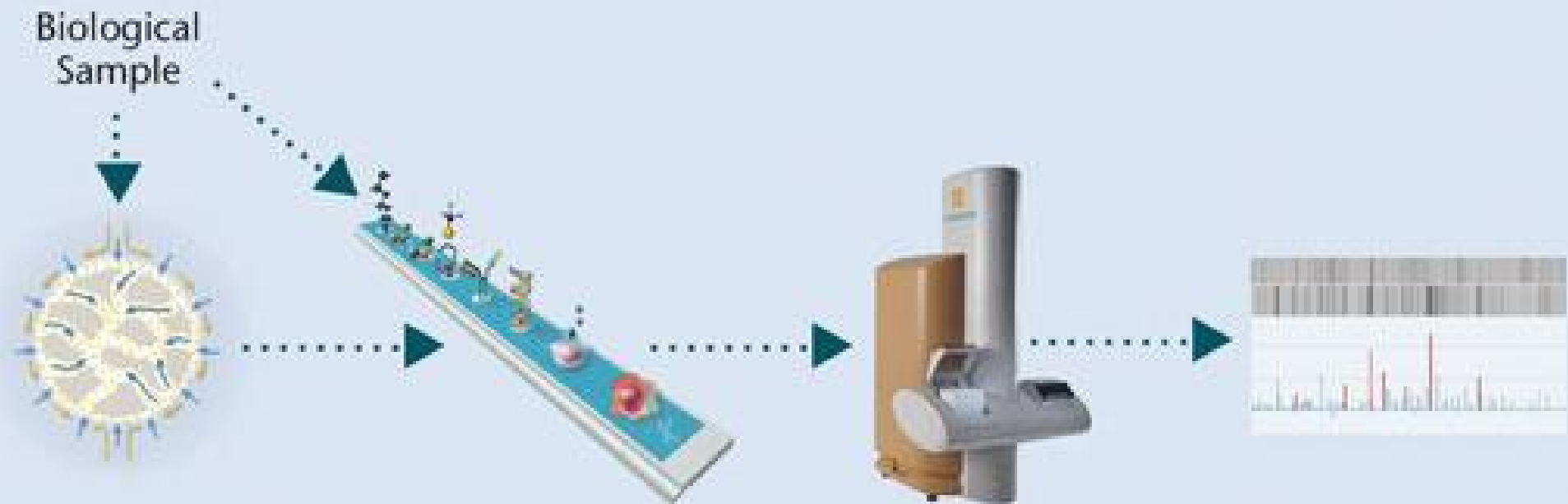

Whole Cell analysis

Microfluidics in a Chip for Proteomics

Biochip-IMB, *Ltd.*



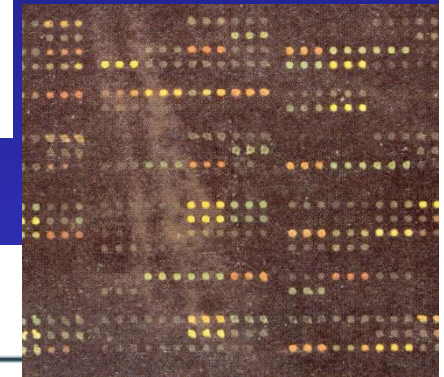
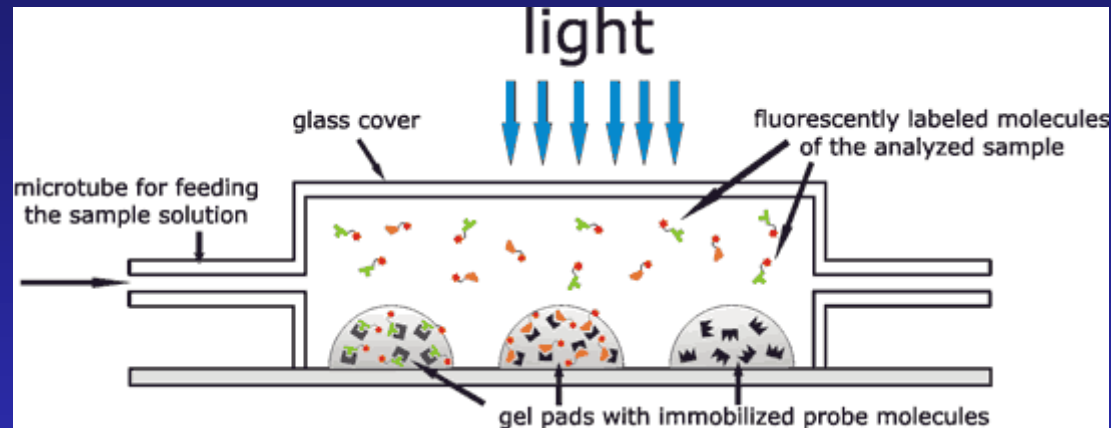
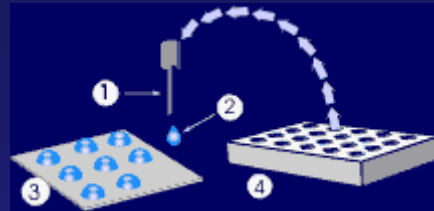
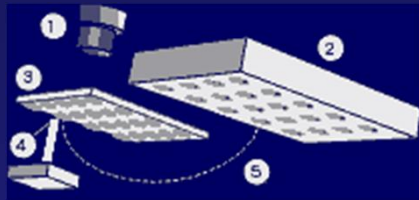

Immobilized antibodies against:	AFP liver cancer	PSA prostate cancer	CA 19-9 pancreas cancer	CEA Intestinal cancer	CA-125 ovarian cancer	CA 15-3 breast cancer	normal
---------------------------------	------------------	---------------------	-------------------------	-----------------------	-----------------------	-----------------------	--------

AFP	• • •						
PSA total		• • •					
CA 19-9			• • •				
CEA				• • •			
CA 125					• • •		
CA 15-3						• • •	
PSA free		• • •					

Biochip-IMB, Ltd.

Express diagnostics tools

CUSTOMIZED

Staphil. enterotoxin
Diphtheria toxin
Tetanus toxin
Lethal factor (anthrax)
Ricin
Viscumin

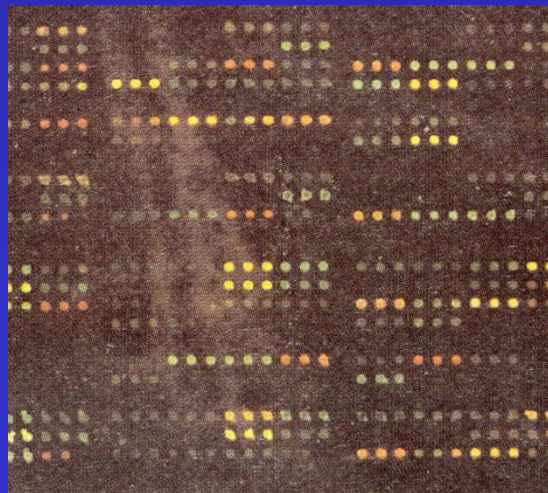
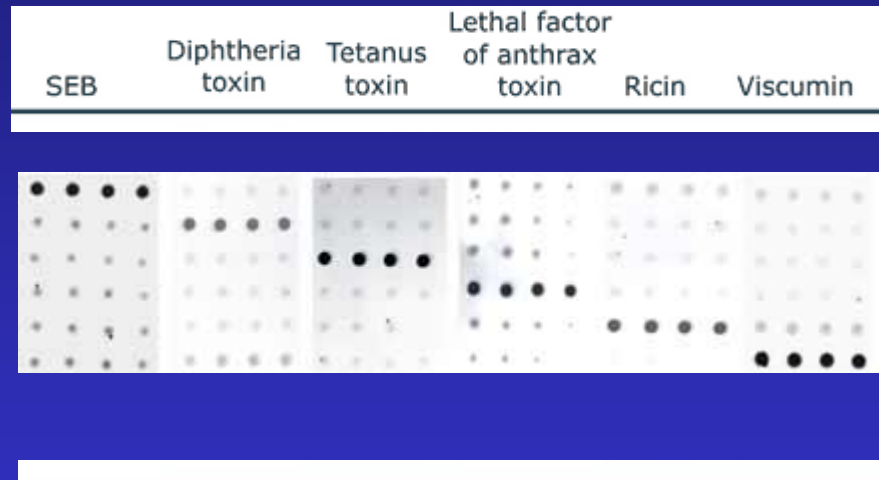

Direct on-chip mass-spectrometry

Protein-ligand interactions

Biotinylated proteins are bound to avidin immobilized in gel pad.

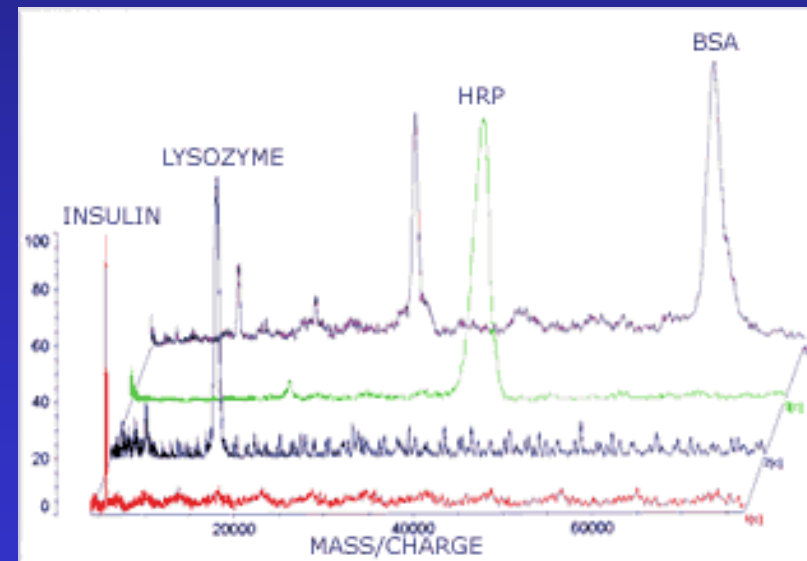

A typical Chip and how to Make it...

Your Lab is Smarter
when your slab gel is digital



The new **Agilent 2100 e-bioanalyzer** offers the same performance and tools for sizing and quantitation of RNA, DNA and proteins that more than 3,000 users have come to appreciate from the **Agilent 2100 bioanalyzer**.



In addition to RNA, DNA and protein analysis, the Agilent 2100 bioanalyzer offers compatibility with flow cytometry assays and tools for 21CFR part 11 compliance.

New Price for the world's best selling Bioanalyzer for electrophoresis!



Experion Automated Electrophoresis Station

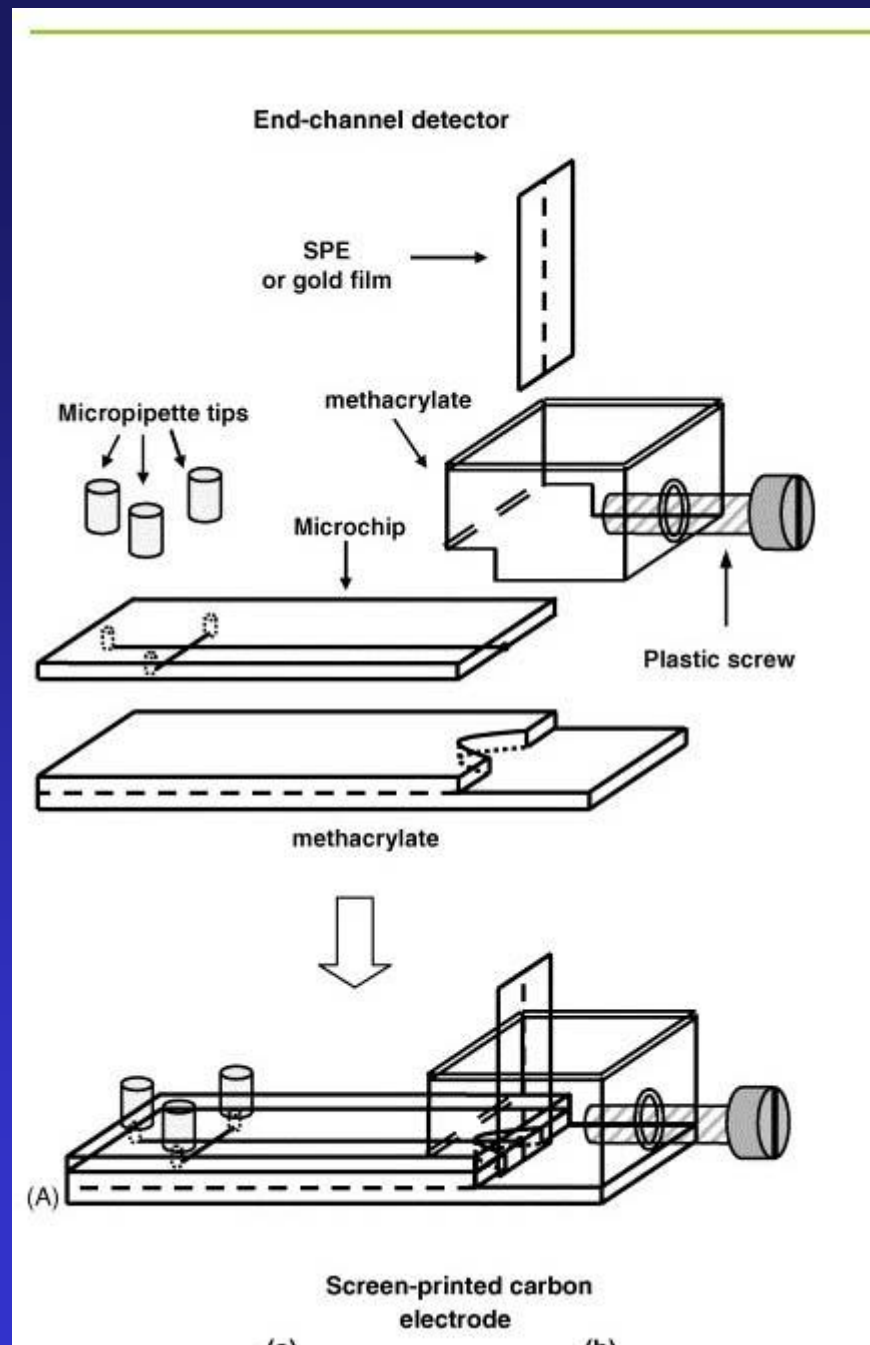

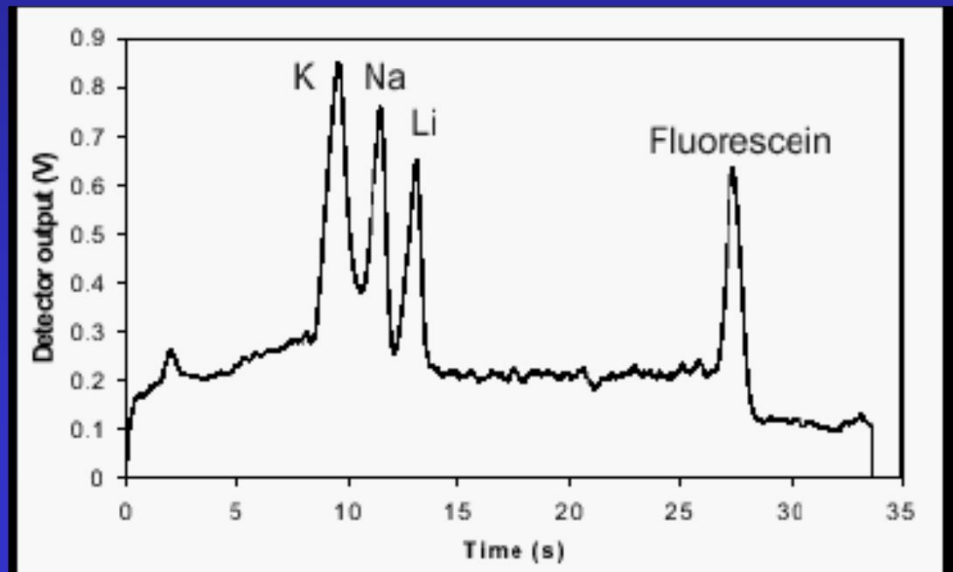
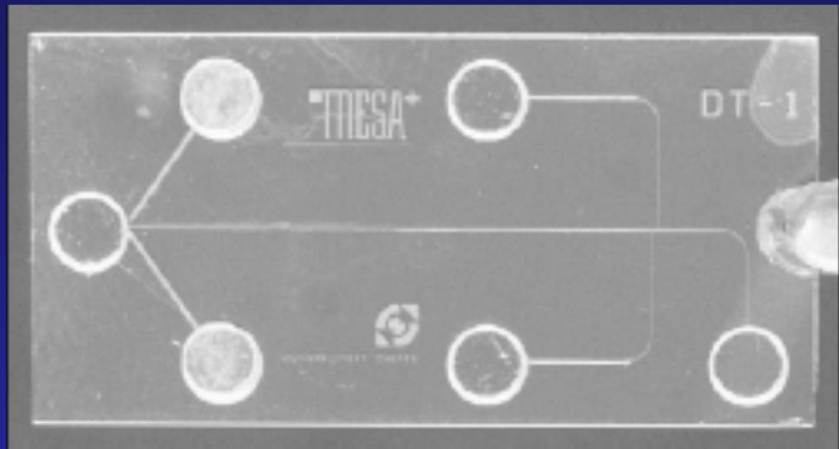

Micro-Array technology in Proteomics

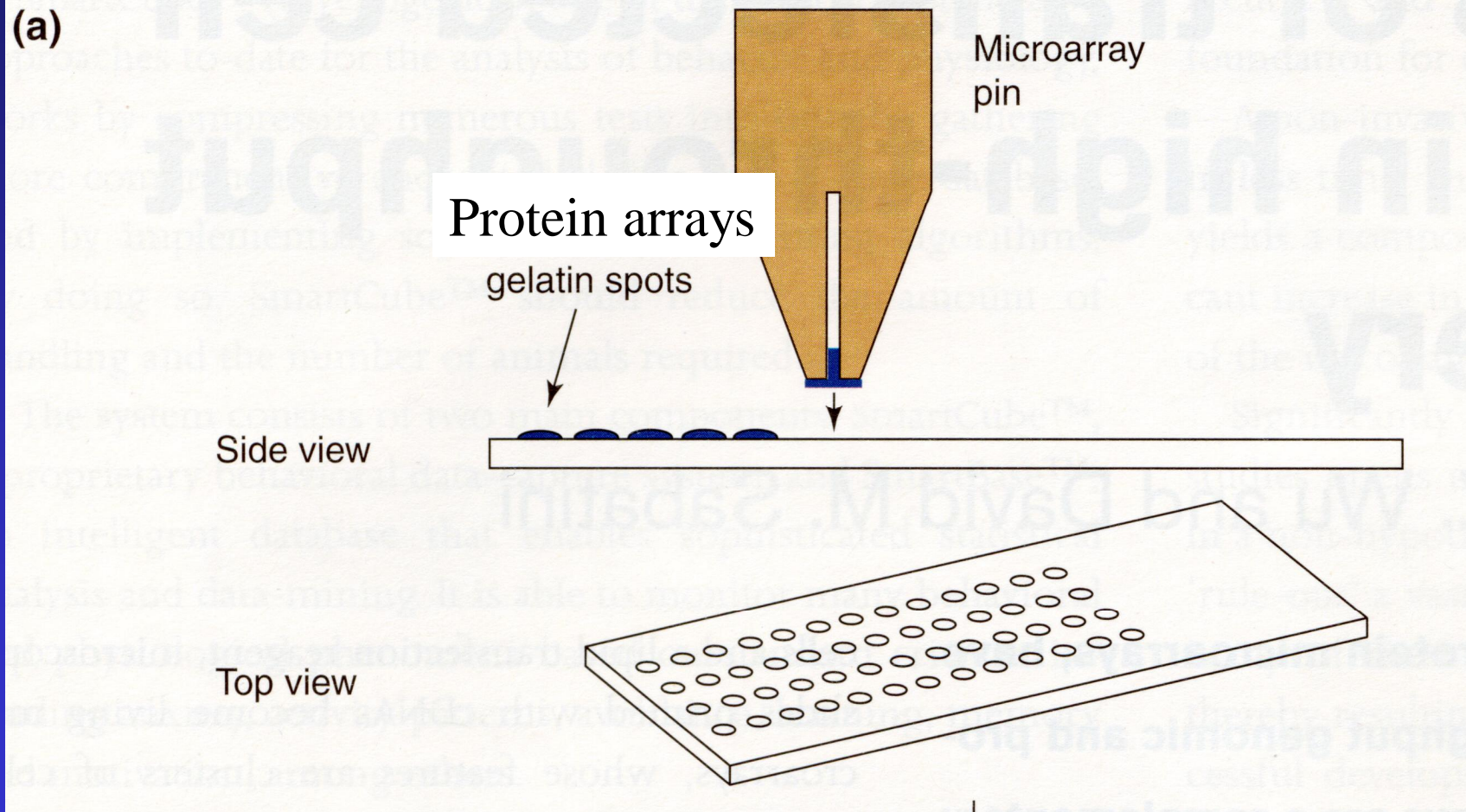

Ab-micro array

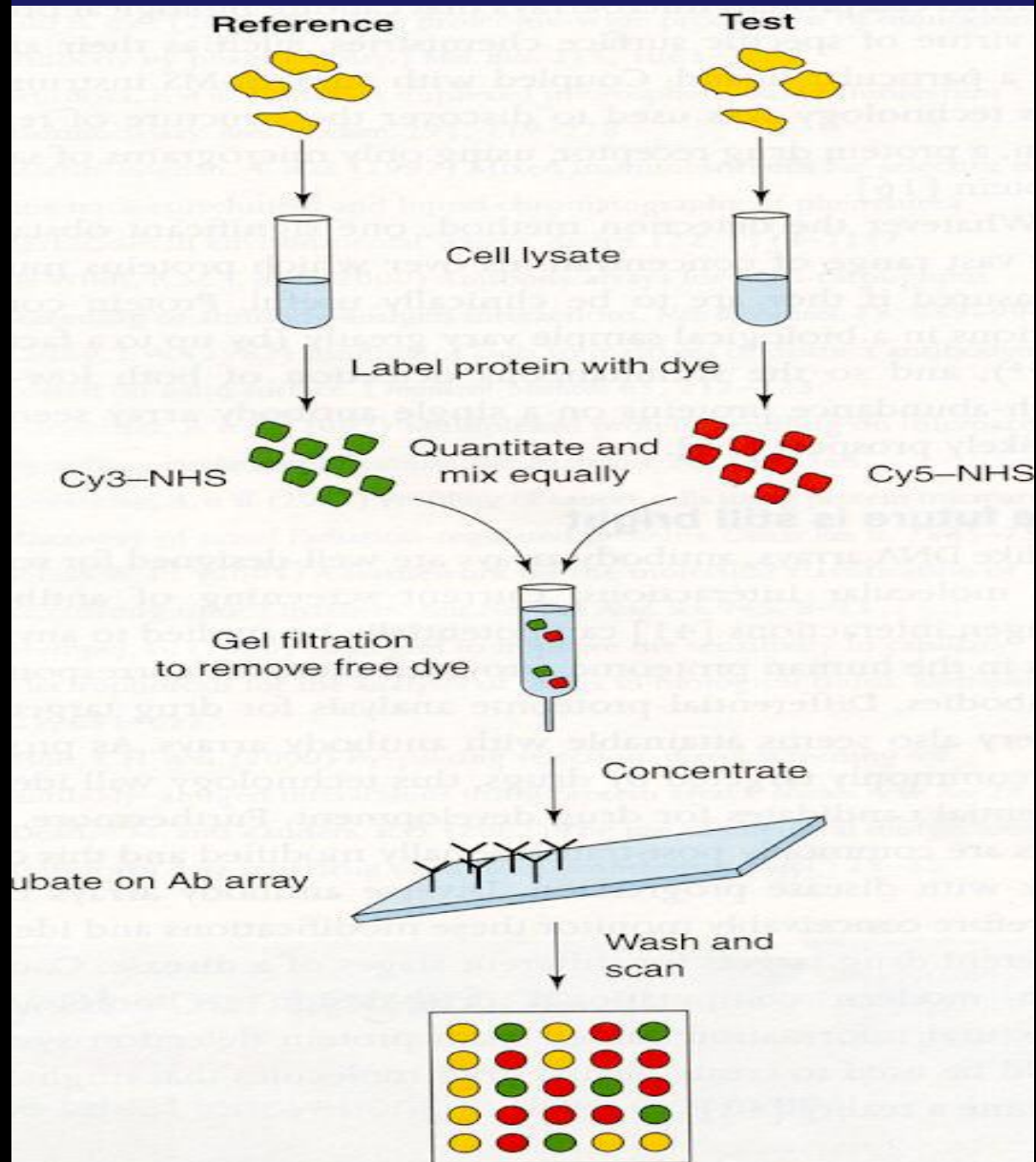

Micro-Array technology in Proteomics

Protein Array

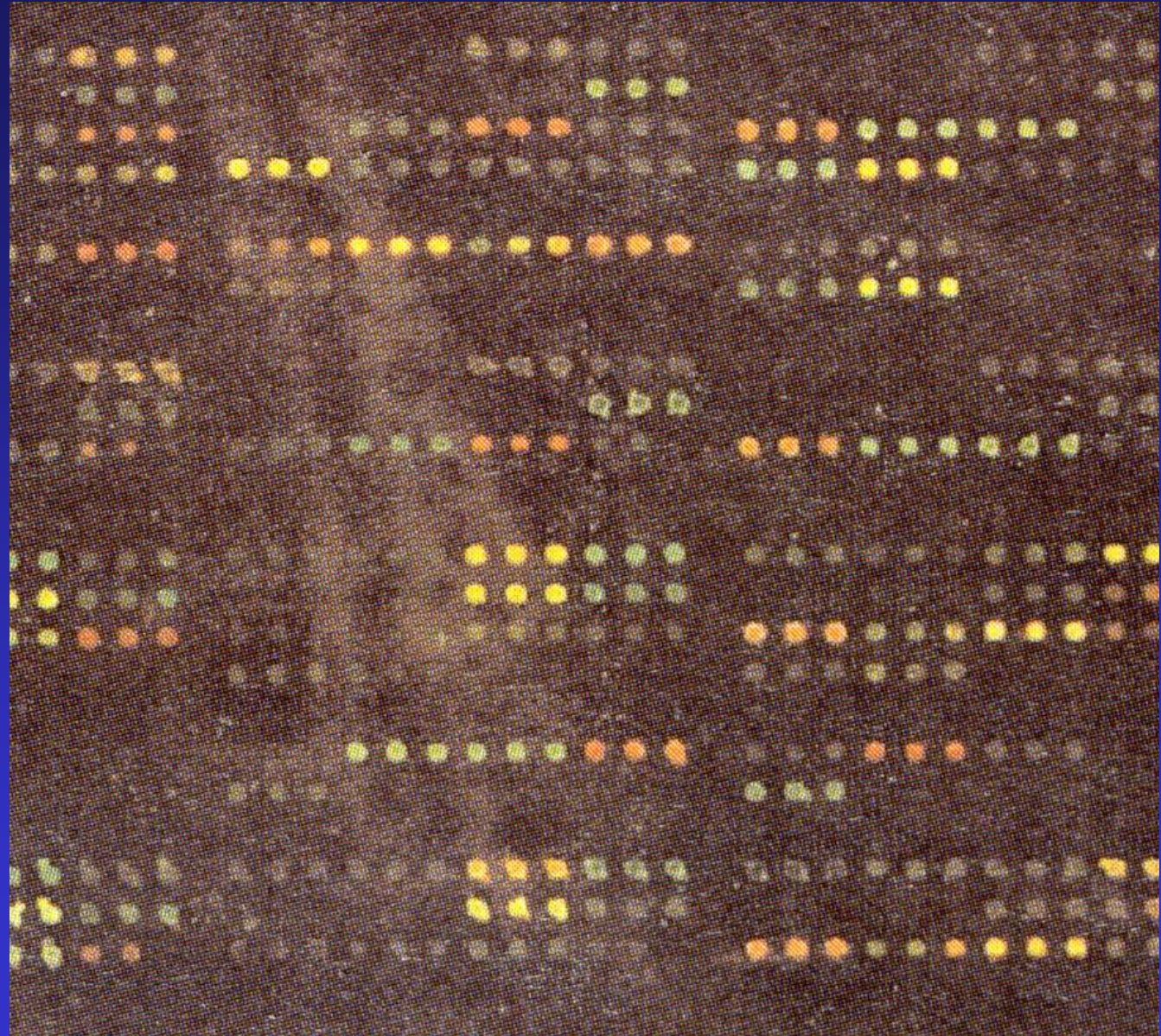

A.

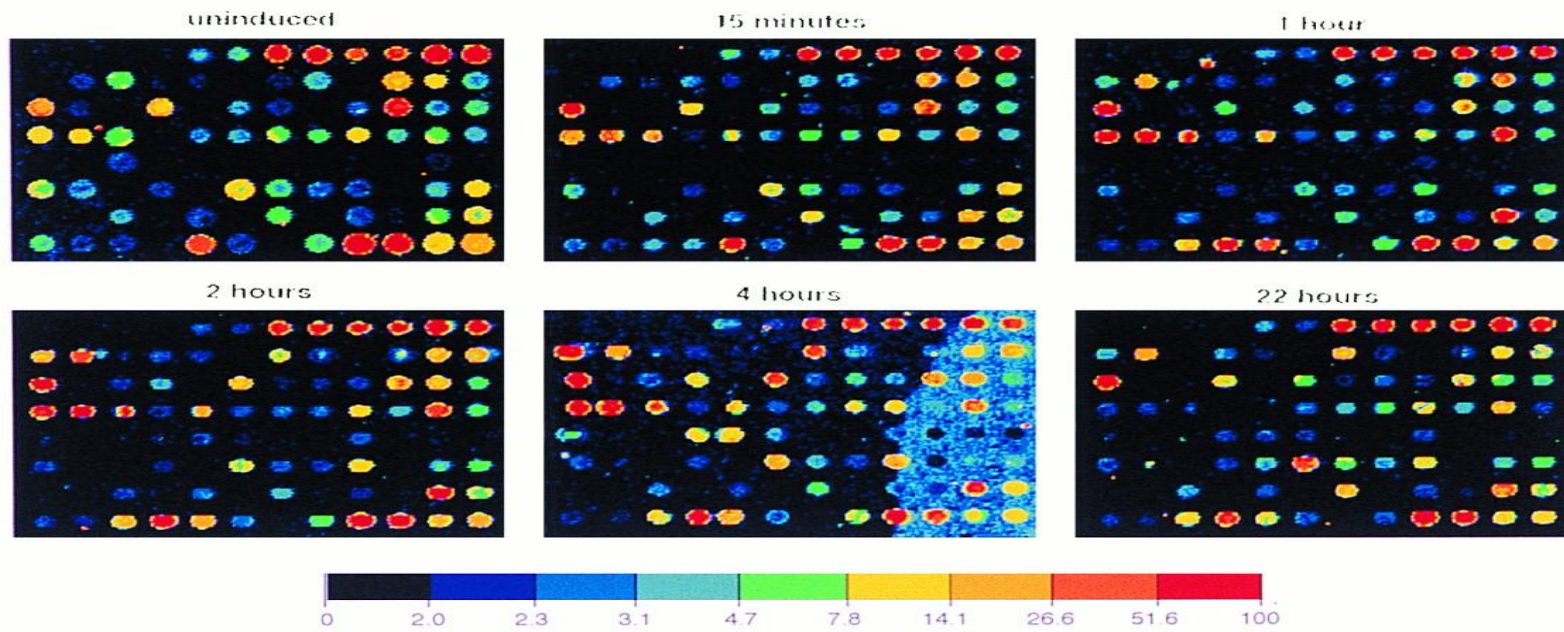

B.

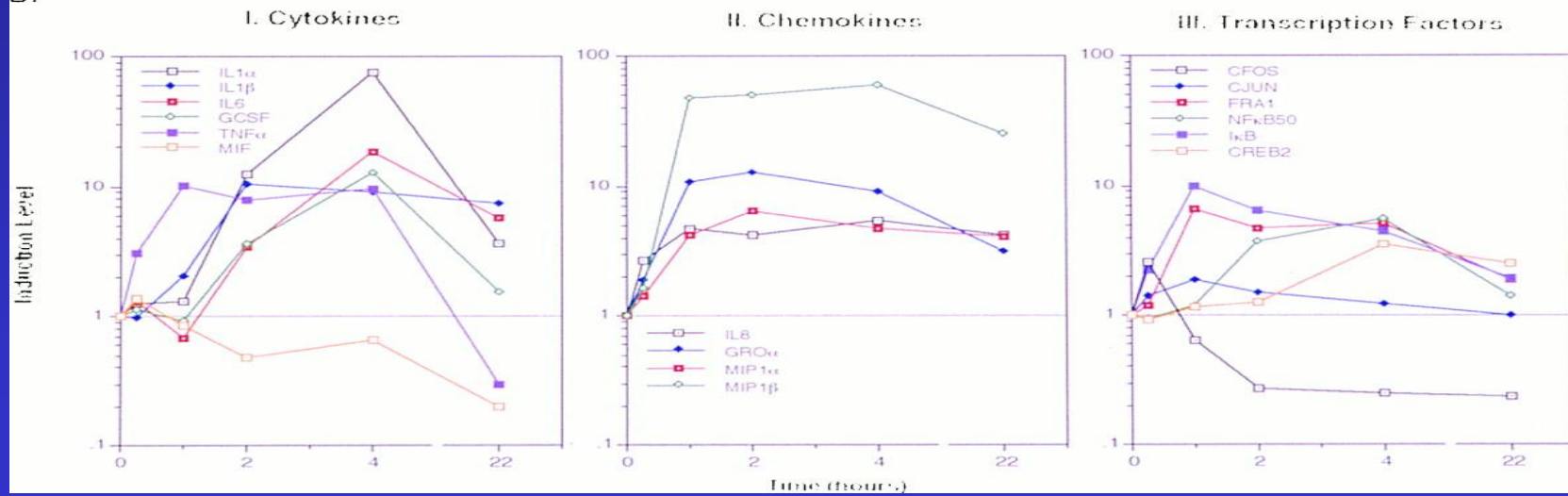

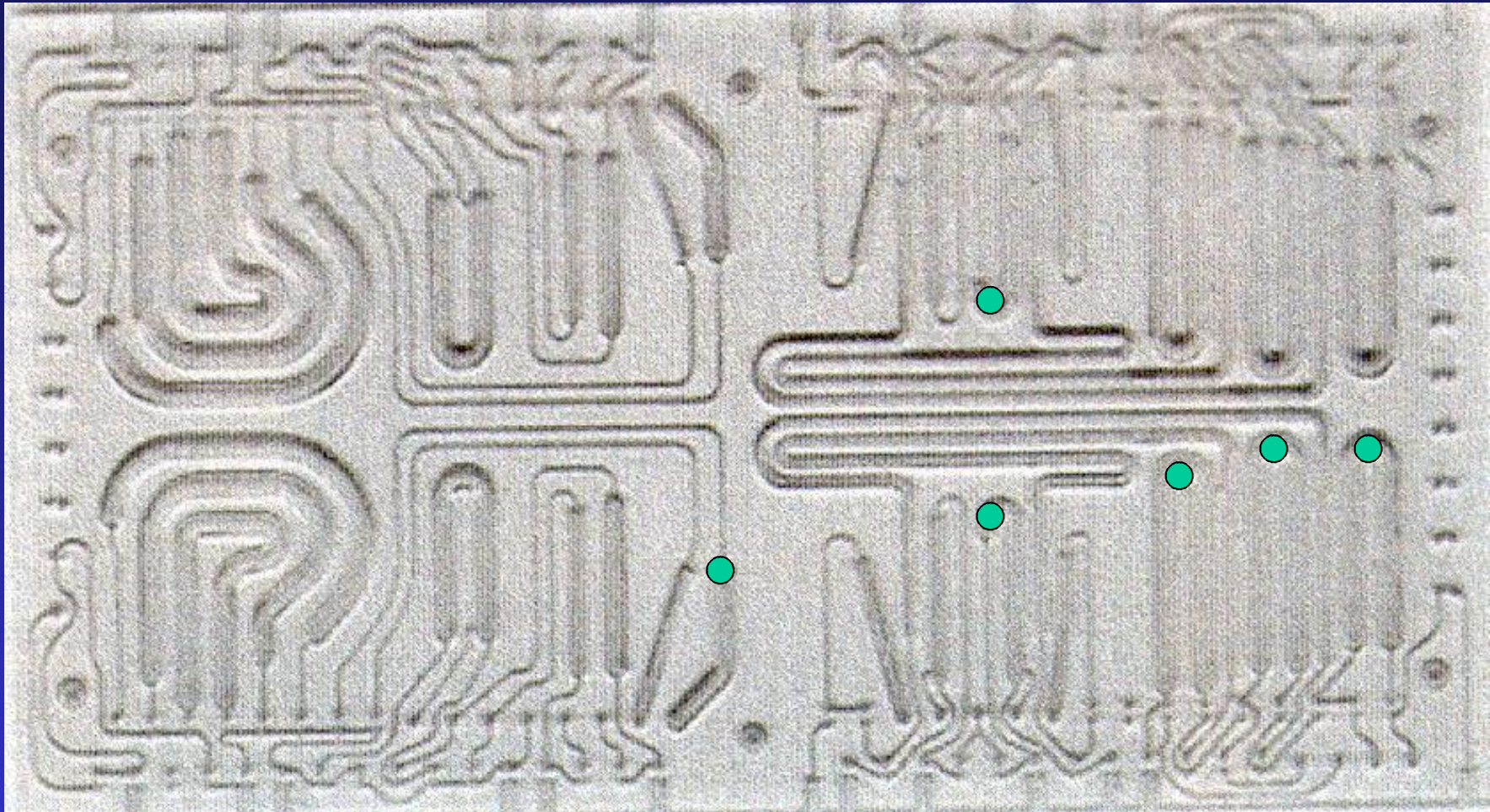

Air Bubble Control System

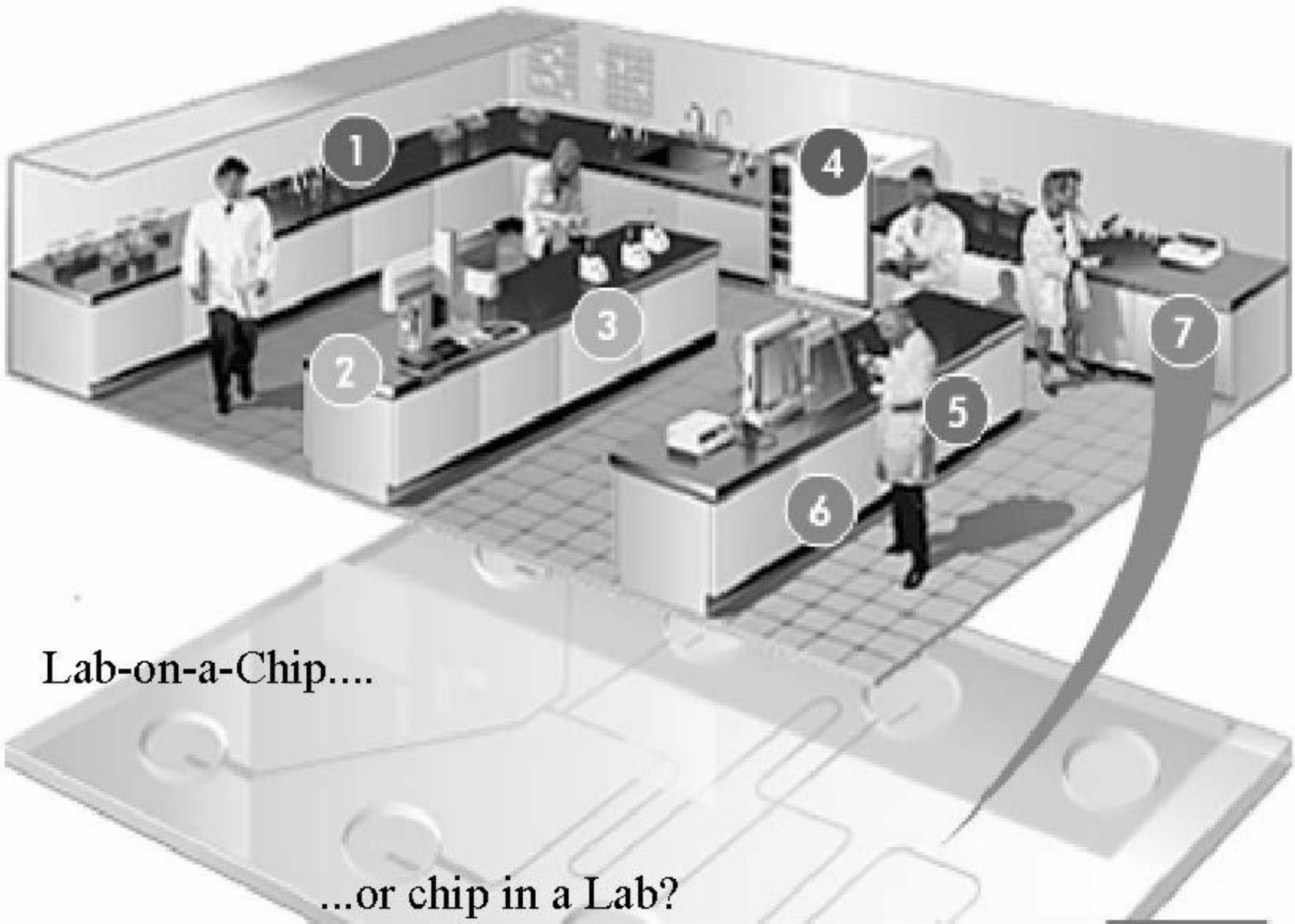

Lab on a Chip course, Finland, 2006

The Goal in Microfabrication...?

The Factory...

